

Kooper 74" Sofa

Model: OP-AWSOF74-KPR

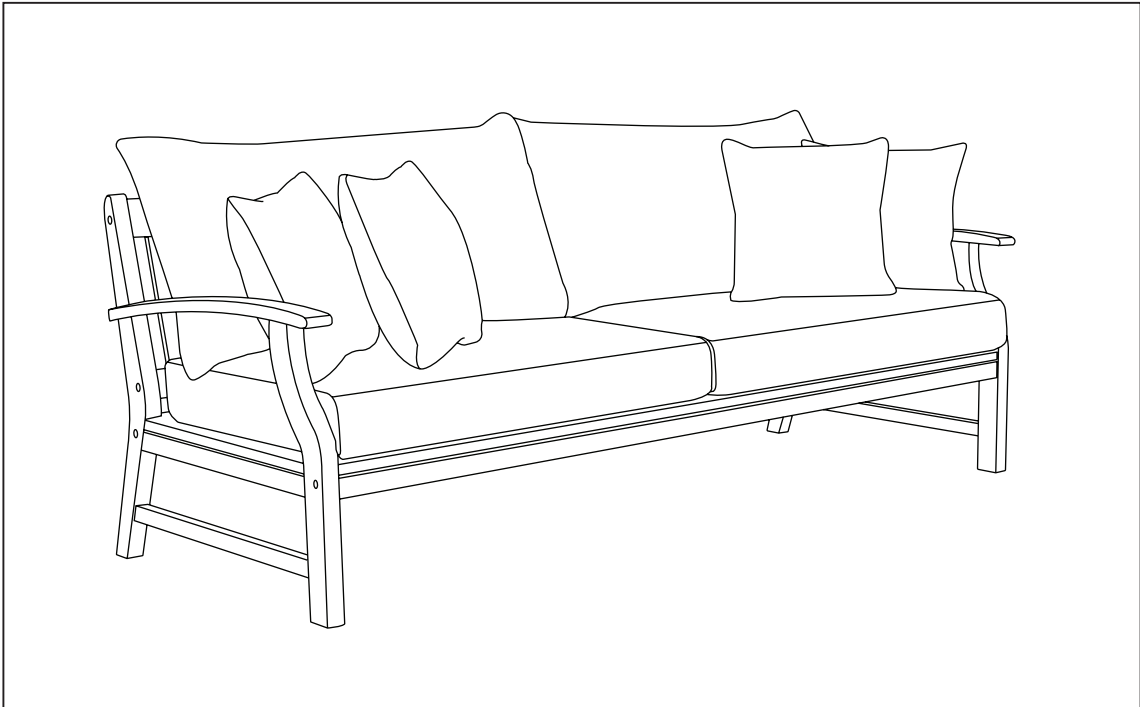







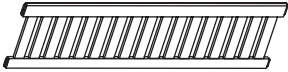
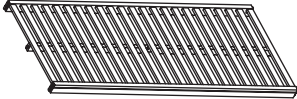

ASSEMBLY INSTRUCTIONS

**IMPORTANT, RETAIN FOR FUTURE REFERENCE.
READ CAREFULLY.**

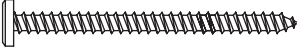
For assistance with assembly or customer service,
call 1-877-924-2090 (English) Monday-Friday, 8 a.m. to 5 p.m. Mountain
Time, North America. Email: customerservice@rstbrands.com or visit
our website at www.rstbrands.com

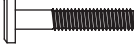

PARTS LIST

NO.	PICTURE	PART DESCRIPTION	QTY.
A		Sofa back	1
B		Sofa seat	1
C		Leg frame	2
D		Post leg	2
E		Screw (M7 x 90)	4
F		Bolt (M8 x 80)	4
G		Barrel nut	4
H		Bolt (M6 x 35)	4
I		Cap for (M6 x 35) bolts	4
J		Bolt (M8 x 40)	1
K		Plastic cap	8
L		Allen wrench	2

Step 1.

ATTACH SEAT TO LEG FRAME - Attach seat (B) to leg frame (C) using bolts (F), barrel nuts (G), and allen wrench (L).

ATTENTION: Use bolt (J) as an extension to insert barrel nut (G) into the hole found on seat (B). Screw the bolt into the top of the barrel nut. Once bolt (F) is secured through the frame and into the barrel nut (G), remove bolt (J) from barrel nut (G).

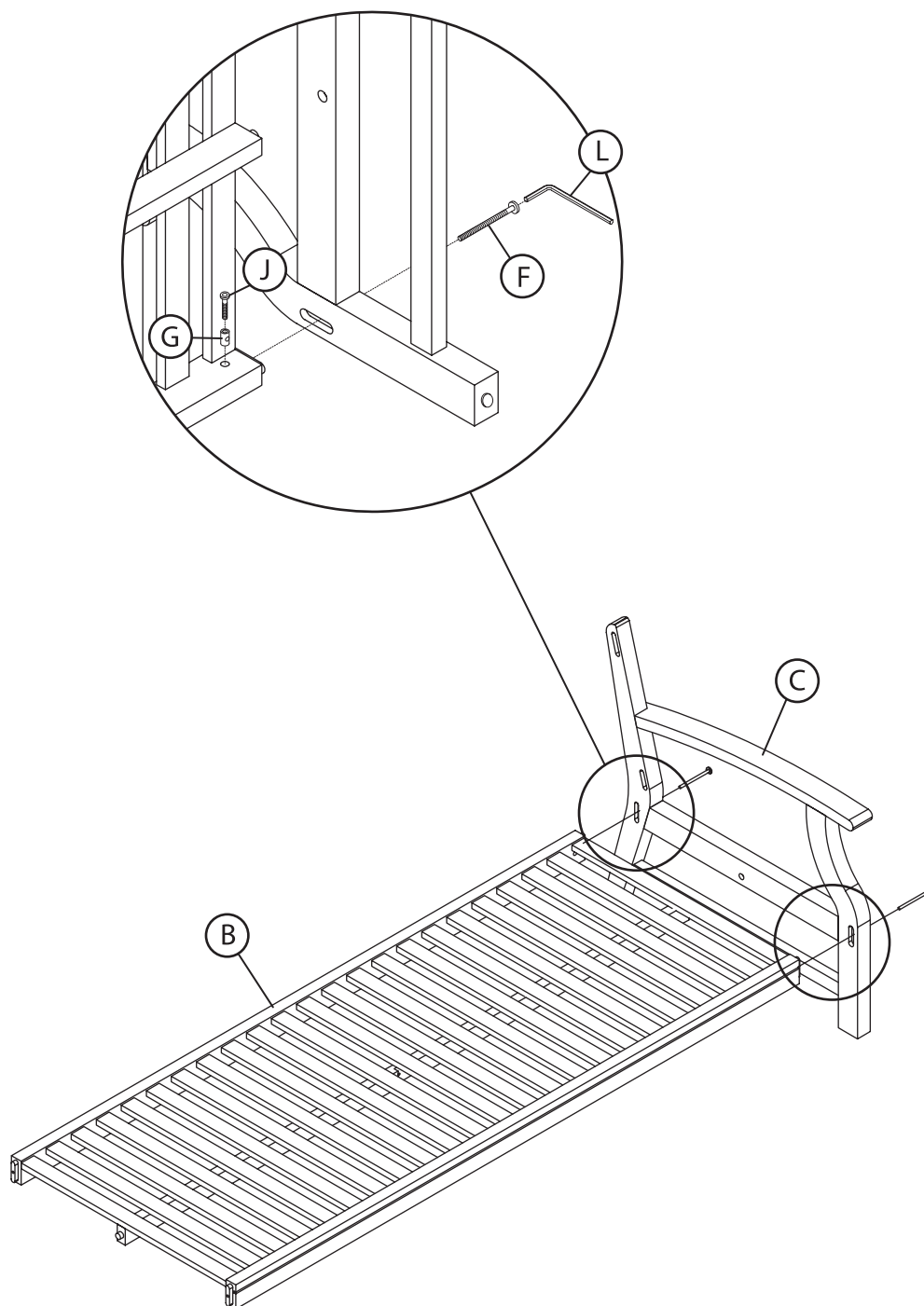

Step 2.

ATTACH BACK TO LEG FRAME- Attach back (A) to leg frame (C) using screws (E) and allen wrench (L).

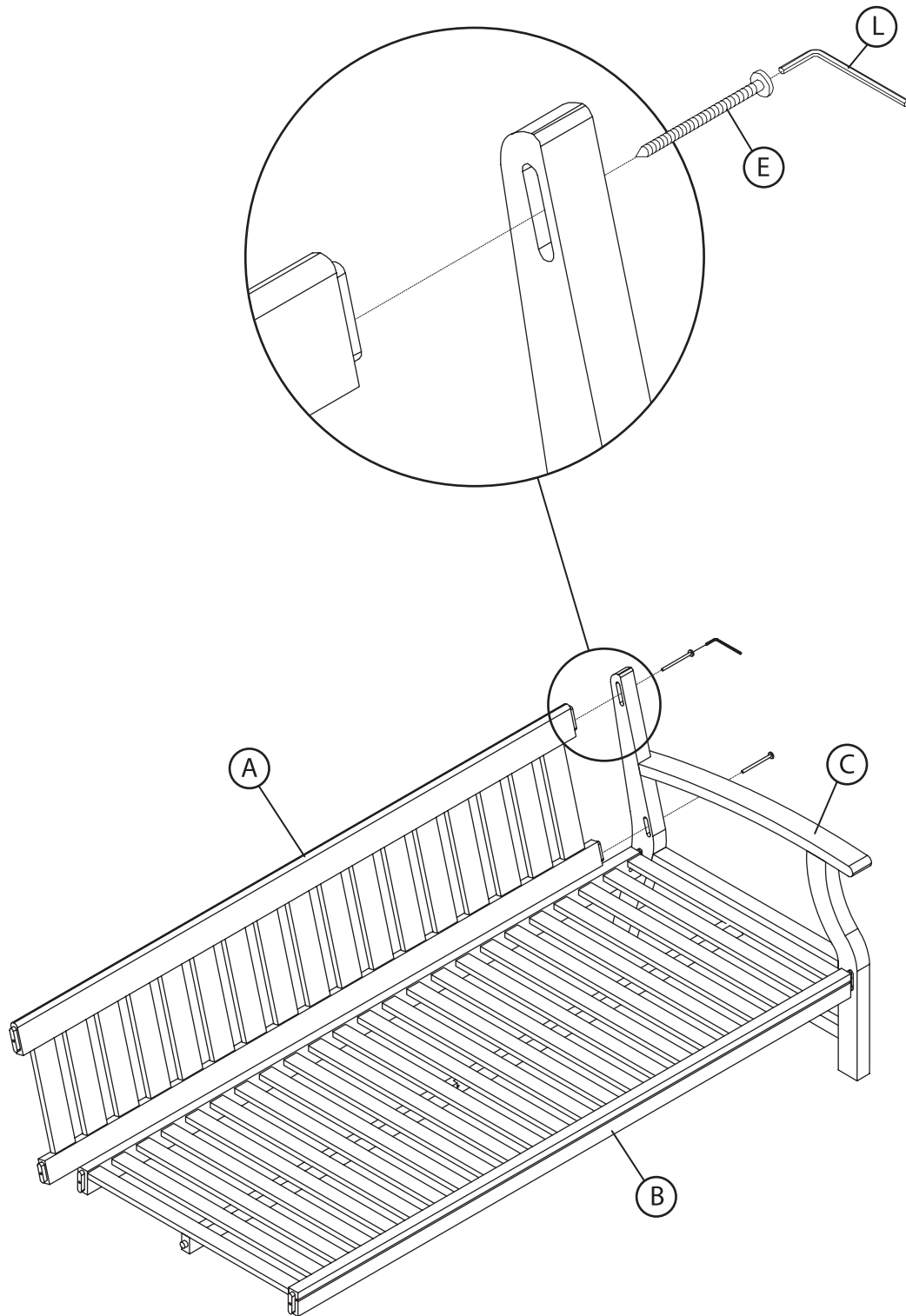

Step 3.

ATTACH SEAT AND BACK TO REMAINING LEG FRAME- Repeat steps 1 and 2 to attach seat (B) and back (A) to remaining leg frame (C).

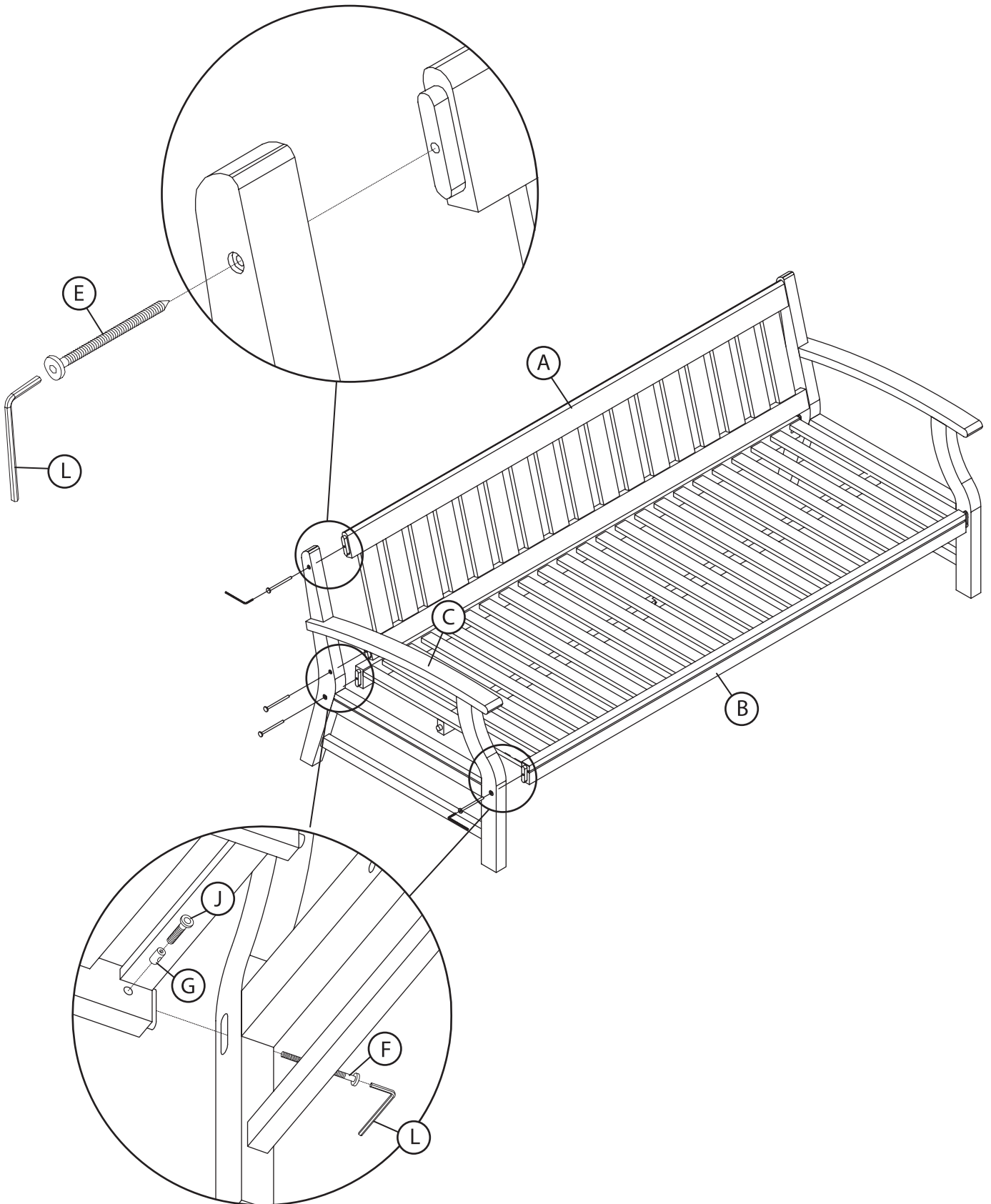

Step 4.

ATTACH POST LEGS TO SEAT- Attach post legs (D) to the bottom of seat (B) using bolts (H), bolt caps (I), and allen wrenches (L).

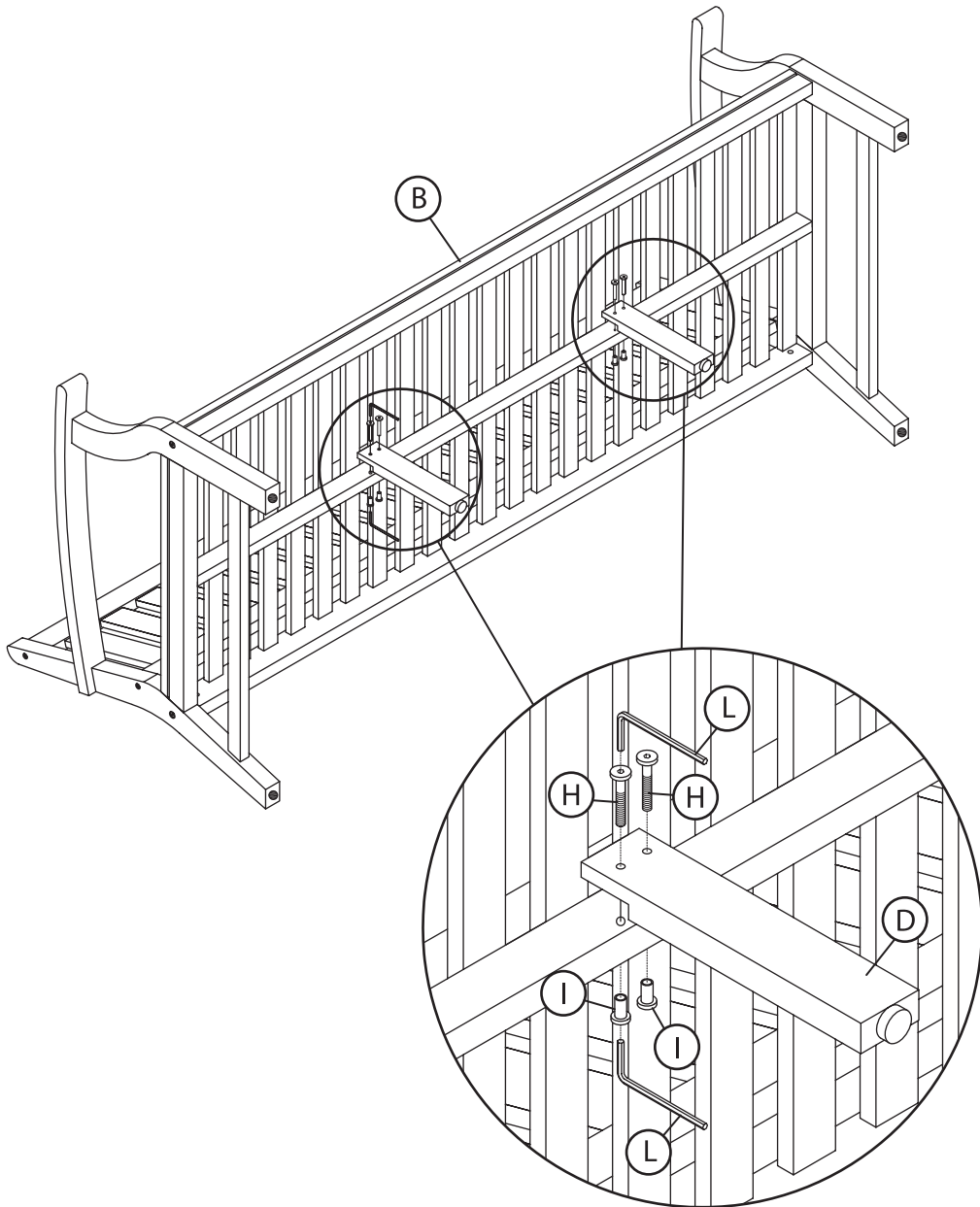

Step 5.

INSERT PLASTIC CAPS INTO BOLT HEADS- Insert plastic caps (K) into exposed bolt heads found on the chair's leg frames.

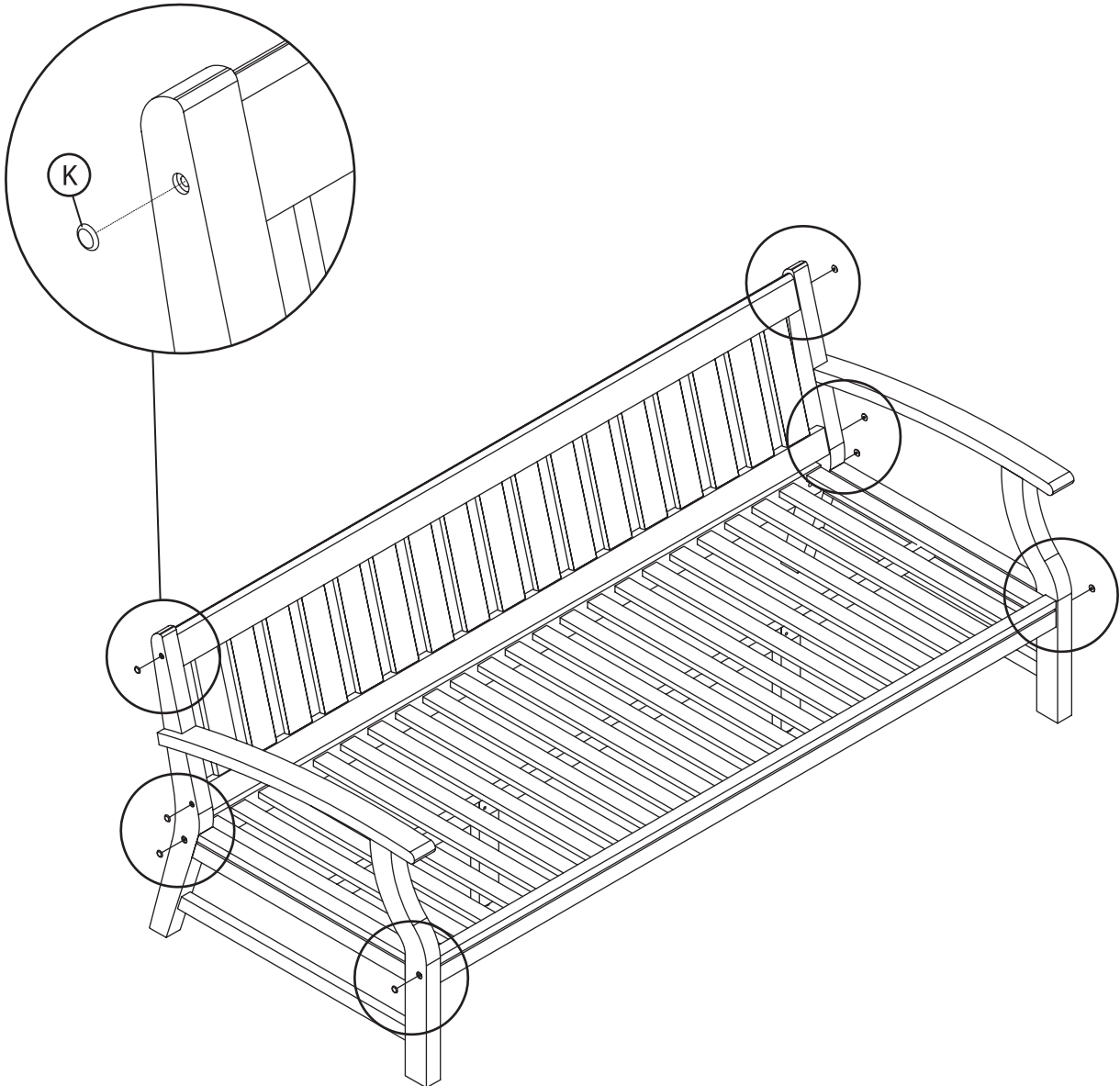

Care and Maintenance

All outdoor furniture is subject to UV rays and weather elements. In order to keep your furniture as long lasting and vibrant as possible, we advise using furniture covers or storing the furniture when not in use. For more information about the materials used to make our furniture please visit www.rstbrands.com/details-landing

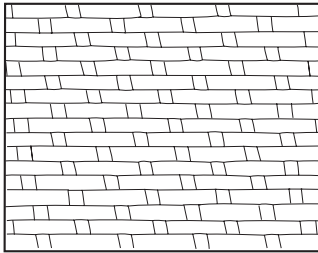

WICKER

Simply washing your wicker with a mild detergent and protecting it as much as possible by covering and or storing it when not in use for long periods of time is sufficient.

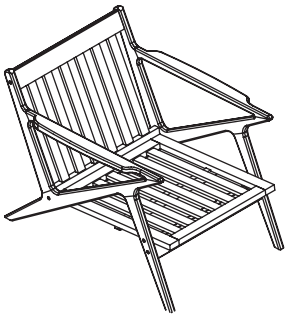

WOOD FRAMES

Make sure all surfaces are protected from heat and liquids. Wipe up spills immediately and do not place furniture next to a heat source such as radiators or fires. All timber surfaces may change color. Spray polishes are best to avoid as they contain silicones which may spoil the surface by building up overtime. Check bolts and screws regularly and tighten when necessary.

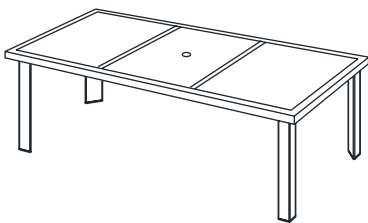

STONE TOPS/ TABLE TOPS

Spills should be wiped up quickly to avoid any staining on the surface. Regular cleaning with mild soap and water with a sponge or soft scrub brush is all that is required. Storing or covering your natural stone top when not in use for extended periods of time is recommended.

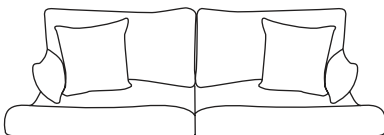

FABRICS

Wipe off spills with a cloth and water. RST Brands uses Sunbrella® fabrics designed to protect and last for several years. Sunbrella fabrics are treated with a proprietary water and stain repellent. If needed to revive fabrics Glen Raven® recommends 303® Fabric Guard™. For more information visit www.303products.com and follow instructions on the container.

Sofá Kooper 74" (1.88 m)

Modelo: OP-AWSOF74-KPR



MANUAL DE INSTRUCCIONES Y ENSAMBLE







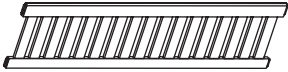
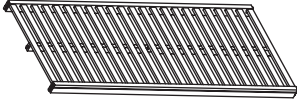

**IMPORTANTE, RETENER PARA FUTURAS CONSULTAS.
LEA CUIDADOSAMENTE**

Para asistencia con el ensamblaje e instalación de las partes y servicio al cliente llame:
1-877-924-2090 (Inglés) Lunes-Viernes 8 a.m- 5 p.m. Hora de la Montaña, Norte América.

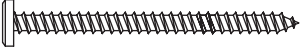
Póngase en contacto con nosotros por correo electrónico a customerservice@www.rstbrands.com
o visite nuestro sitio web en www.rstbrands.com.

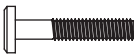

SILLA LISTA DE PARTES

NO.	IMAGEN	DESCRIPCIÓN (PARTE)	CANT.
A		Respaldo del sofá	1
B		Asiento del sofá	1
C		Estructura de la pata	2
D		Pata posterior	2
E		Tornillo (M7 x 90)	4
F		Perno (M8 x 80)	4
G		Tuerca cilíndrica	4
H		Perno (M6 x 35)	4
I		Tapa para tornillos (M6 x 35)	4
J		Perno (M8 x 40)	1
K		Tapa de plástico	8
L		Llave Allen # 4	2

Paso 1.

UNA EL ASIENTO A LA ESTRUCTURA DE LA PATA - Una el asiento (B) a la estructura de la pata (C) utilizando los pernos (F), las tuercas cilíndricas (G) y la llave Allen (L). **Atención:** Use el perno (J) como una extensión para colocar la tuerca cilíndrica (G) en el orificio que se encuentra en el asiento (B). Atornille el perno en la parte superior de la tuerca cilíndrica. Una vez que el perno (F) esté asegurado a la estructura y en la tuerca cilíndrica (G), retire el perno (J) de la tuerca cilíndrica (G).

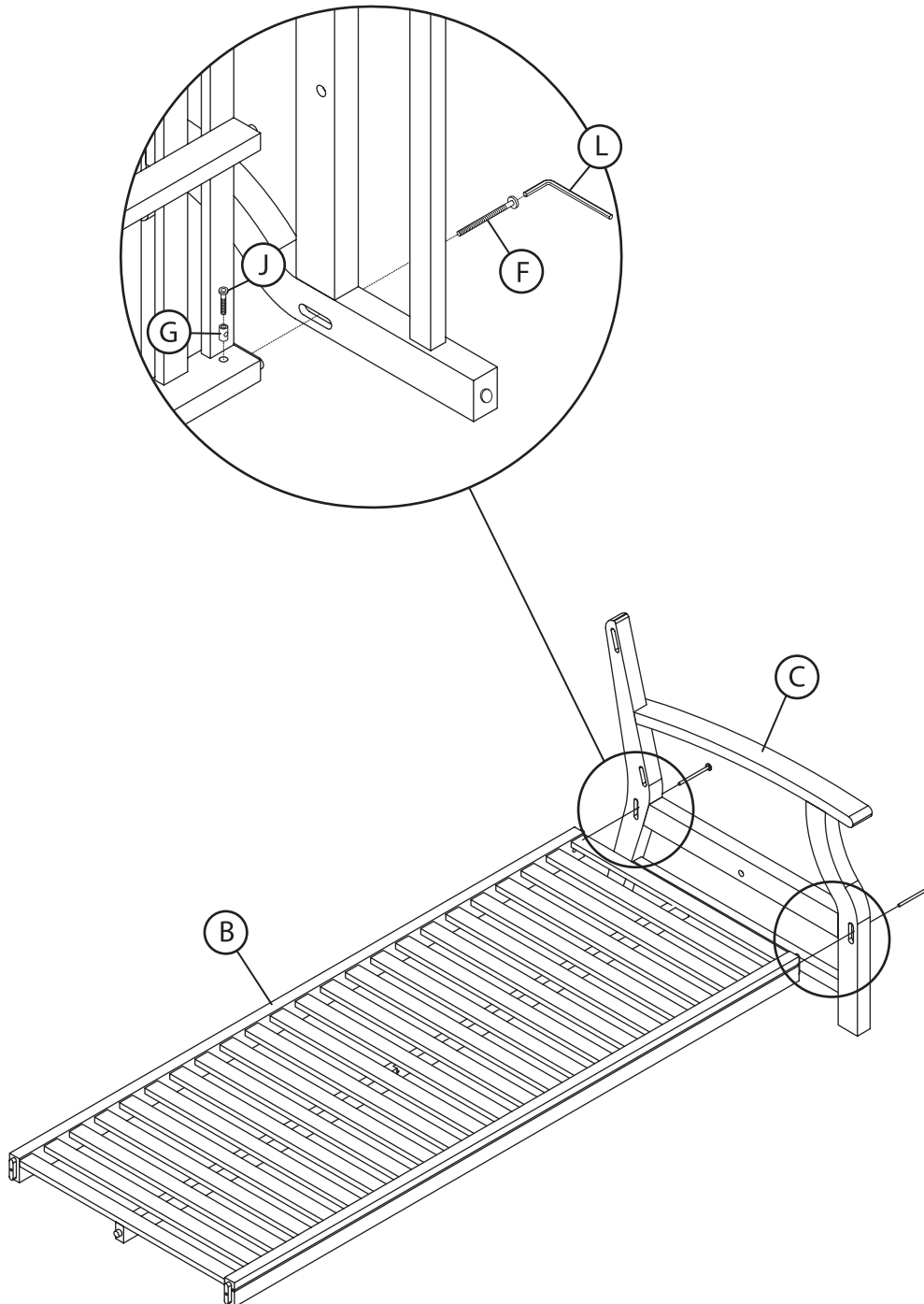

Paso 2.

UNA EL RESPALDO A LA ESTRUCTURA DE LA PATA - Una el respaldo (A) a la estructura de la pata (C) utilizando los tornillos (E) y la llave Allen (L).

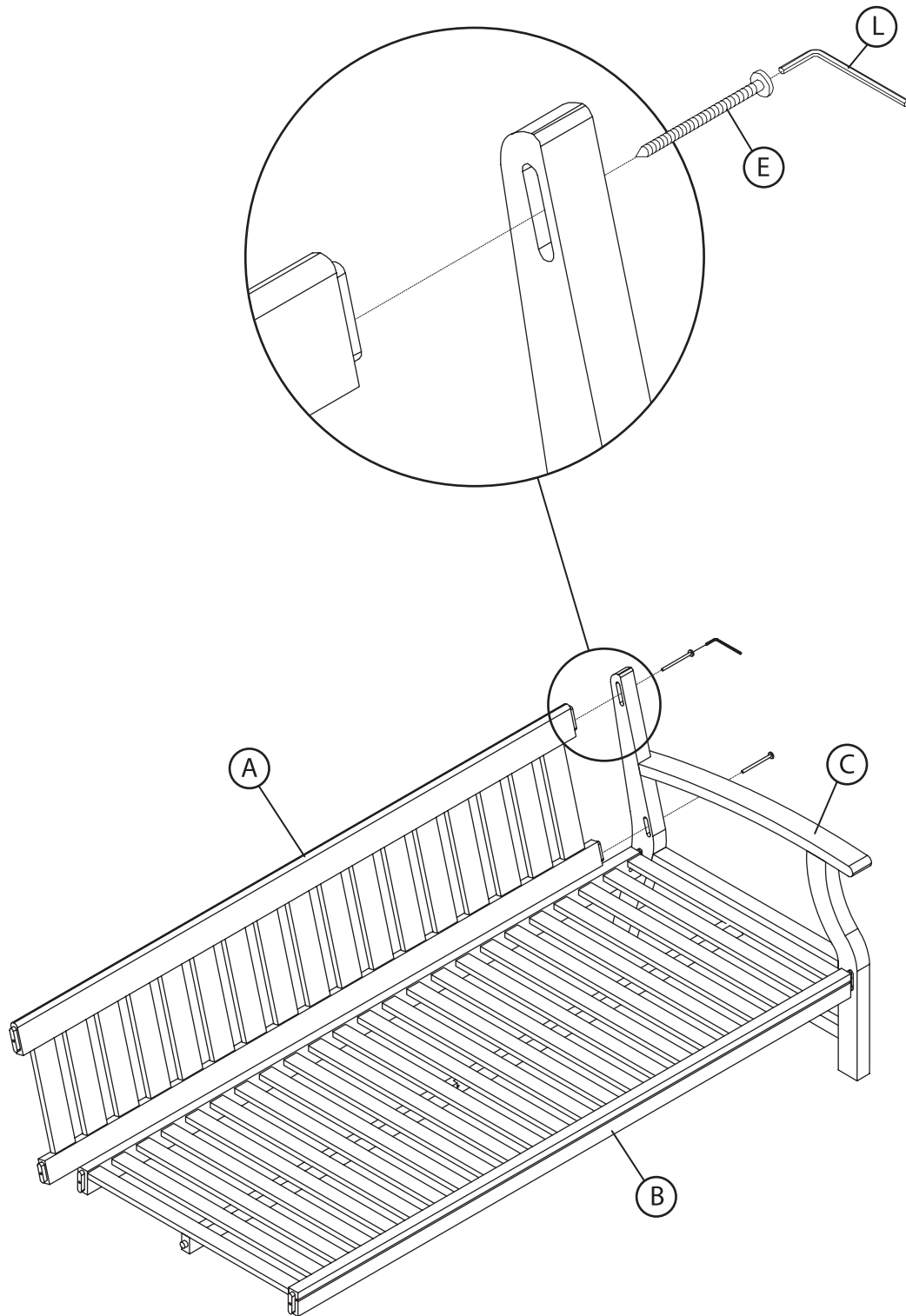

Paso 3.

UNA EL ASIENTO Y EL RESPALDO A LA ESTRUCTURA DE LA PATA - Repita los pasos 1 y 2 para unir el asiento (B) y el respaldo (A) a la estructura de la pata (C).

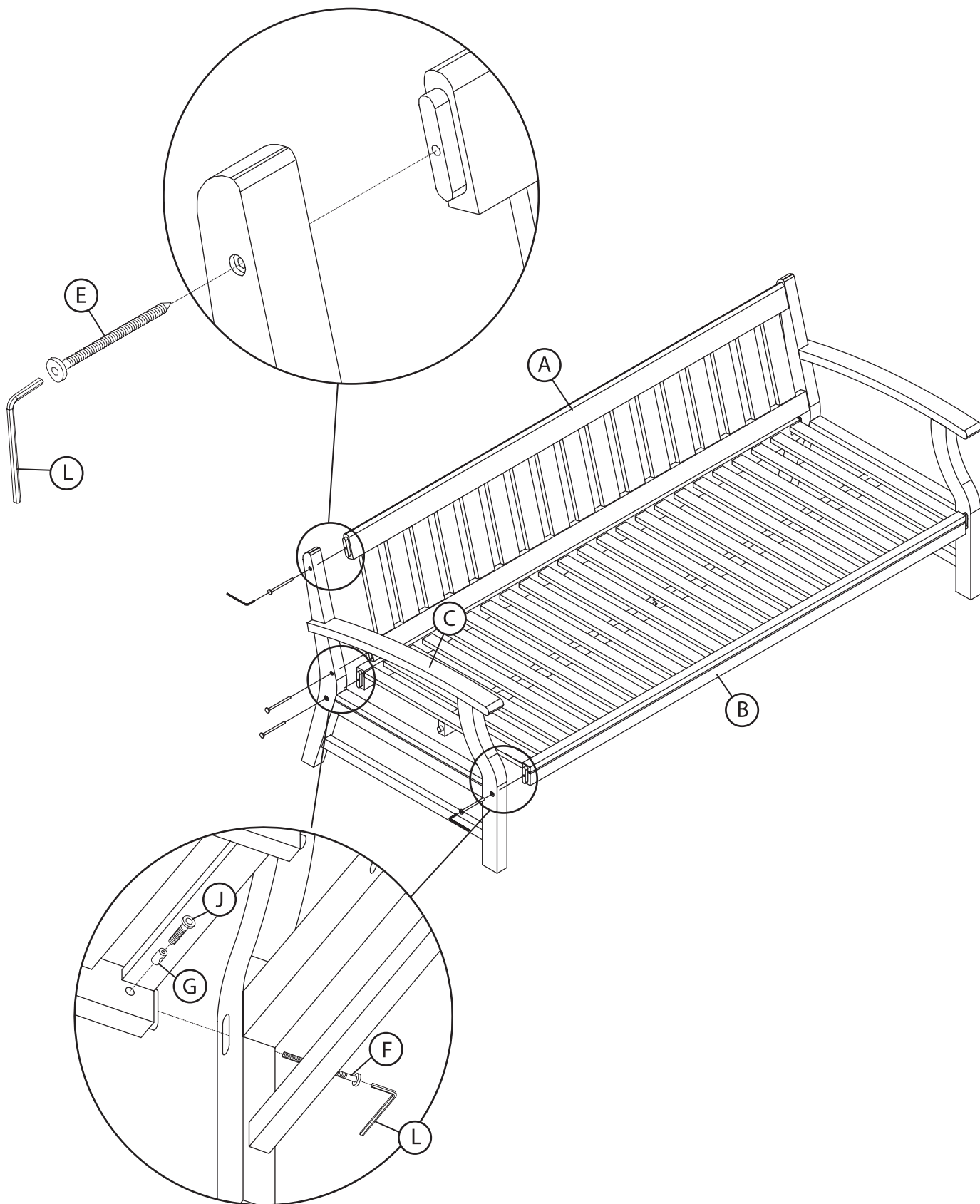

Paso 4.

UNA LAS PATAS POSTERIORES AL ASIENTO - Una las patas posteriores (D) a la parte inferior del asiento (B) utilizando los pernos (H), las tapas de los pernos (I) y las llaves Allen (L).

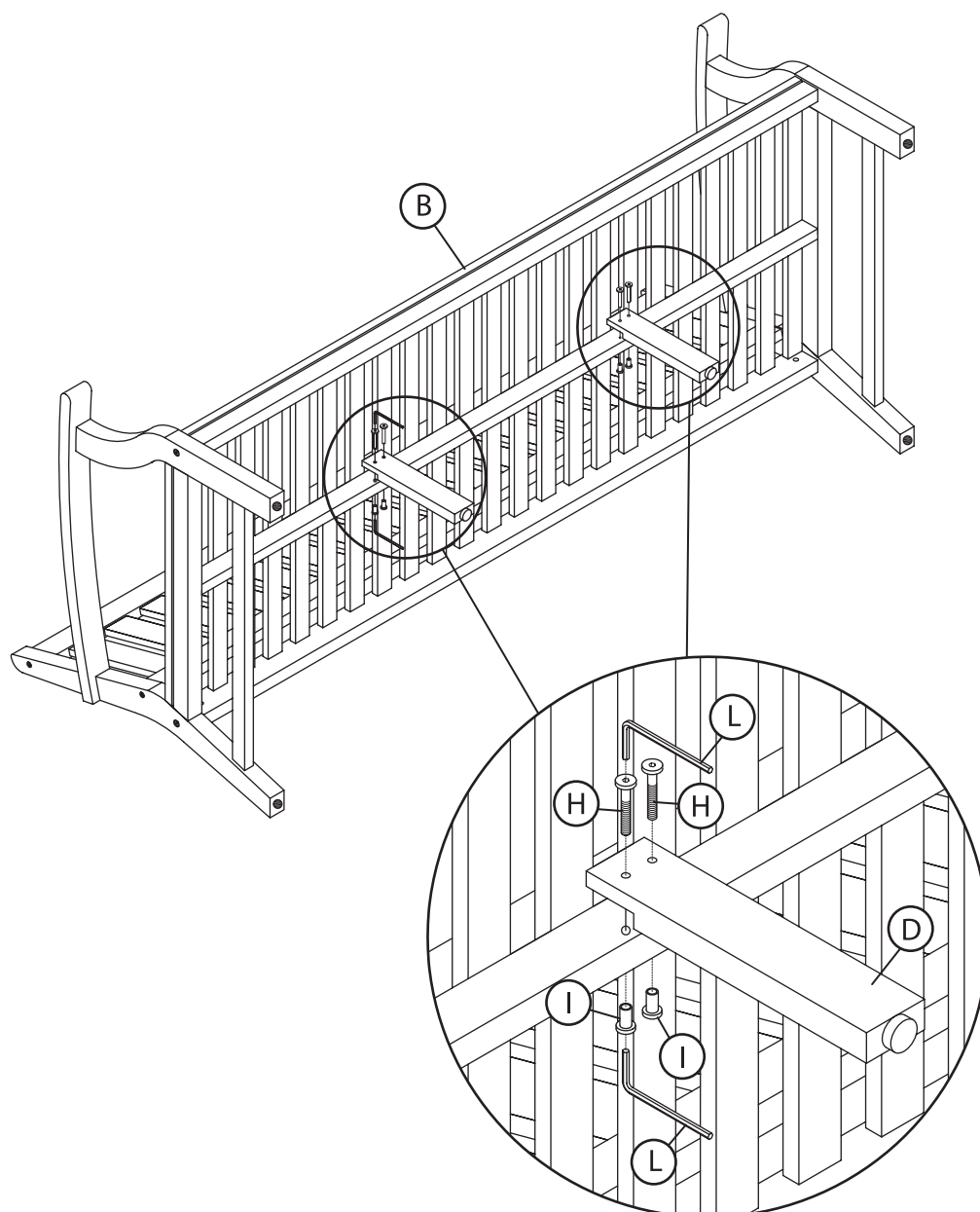

Paso 5.

COLOQUE LAS TAPAS DE PLÁSTICO SOBRE LAS CABEZAS DE LOS PERNOS - Coloque las tapas de plástico (K) sobre las cabezas de los pernos expuestos que se encuentran en las estructuras de las patas.

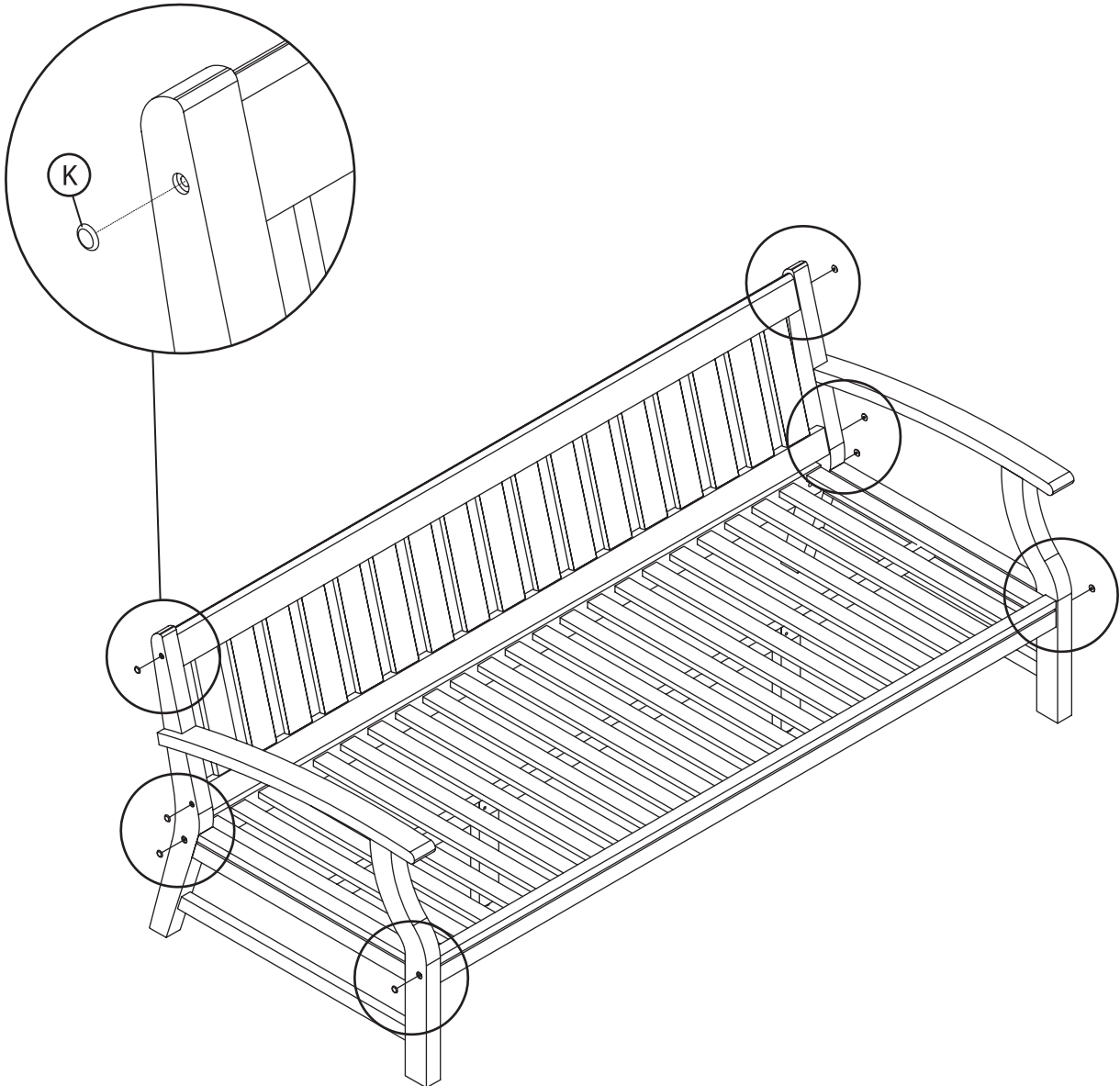

Cuidados y Mantenimiento

Todo mobiliario al aire libre está sujeto a los rayos ultravioleta y las inclemencias meteorológicas. Para que sus muebles duren y los colores se mantengan tan vibrantes como sea posible, aconsejamos cubrirlos o guardarlos cuando no estén en uso. Para obtener más información acerca de los materiales utilizados para fabricar nuestros muebles visite: www.rstbrands.com/details-landing

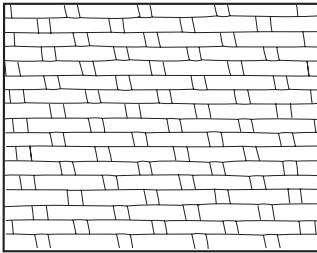

MIMBRE

Simplemente lave sus muebles de mimbre con un detergente suave y protéjalos cubriéndolos o guardándolos cuando no los use durante largos períodos de tiempo.

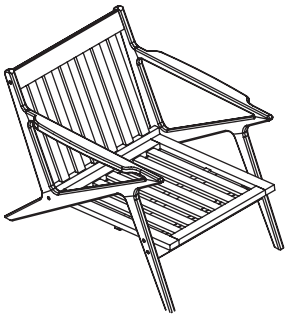

ESTRUCTURAS DE ALUMINIO

Los muebles de RST Brands están contruidos con estructuras recubiertas con polvo de aluminio diseñados para necesitar mantenimiento mínimo. Evite que se acumule demasiada suciedad limpiando con agua y jabón suave. Nunca deje muebles sobre el agua.

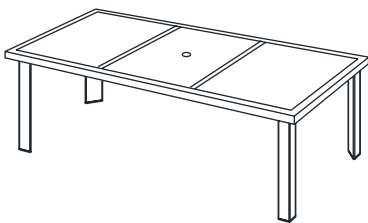

SUPERFICIES DE PIEDRA / MESA

Limpie los derrames rápidamente para evitar manchas en la superficie. La limpieza regular con agua y jabón suave con una esponja o cepillo es todo lo que se necesita. Se recomienda almacenar o cubrir la superficie de piedra natural cuando no está en uso durante períodos prolongados de tiempo.

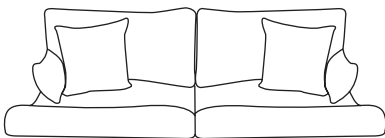

TEJIDOS

Limpie los derrames con un paño y agua. RST Brands utiliza tejidos Sunbrella® que están diseñados para proteger y durar varios años. Los tejidos Sunbrella se tratan con un repelente de agua y manchas de fórmula patentada. Si es necesario para reavivar los tejidos Glen Raven® se recomienda usar 303© Fabric Guard™. Para obtener más información, visite www.303products.com y siga las instrucciones en el envase.

Canapé Kooper 74" (188 m)

Modèle: OP-AWSOF74-KPR









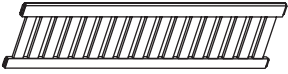
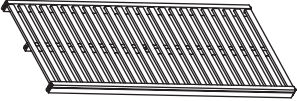

INSTRUCTIONS D'ASSEMBLAGE

**IMPORTANT, À CONSERVER À TITRE DE RÉFÉRENCE.
À LIRE ATTENTIVEMENT.**

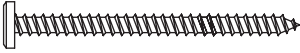
Pour de l'aide à l'assemblage ou le service à la clientèle, composez le 1-877-924-2090 (Anglais) Lundi - Vendredi 8 heures - 17 heures, heure des Rocheuses, en Amérique du Nord.
Émail: customerservice@rstbrands.com ou visitez notre site Web à rstbrands.com

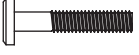

LISTE DES PIÈCES

NO.	IMAGE	RÉFÉRENCE DESCRIPTION	QTÉ
A		Dossier du canapé	1
B		Siège du canapé	1
C		Patte du cadrage	2
D		Patte escamotable	2
E		Vis (M7 x 90)	4
F		Boulon (M8 x 80)	4
G		Écrou à barillet	4
H		Boulon (M6 x 35)	4
I		Capuchon pour boulons (M6 x 35)	4
J		Boulon (M8 x 40)	1
K		Capuchon de plastique	8
L		Clé Allen	2

Étape 1.

ATTACHEZ LE SIÈGE À LA PATTE DE CADRAGE - Attachez le siège (B) à la patte de cadrage (C) en utilisant les boulons (F), les écrous à barillet (G) et la clé Allen (L)

Attention: Utilisez le boulon (J) comme extension pour insérer un écrou à barillet (G) dans le trou situé sur le siège (B). Vissez le boulon dans la partie supérieure de l'écrou à barillet. Une fois que le boulon (F) est fixé à travers le cadrage et dans l'écrou à barillet (G), retirez le boulon (J) de l'écrou à barillet (G). Dans l'écrou à barillet (G), retirez le boulon (J) de l'écrou à barillet (G).

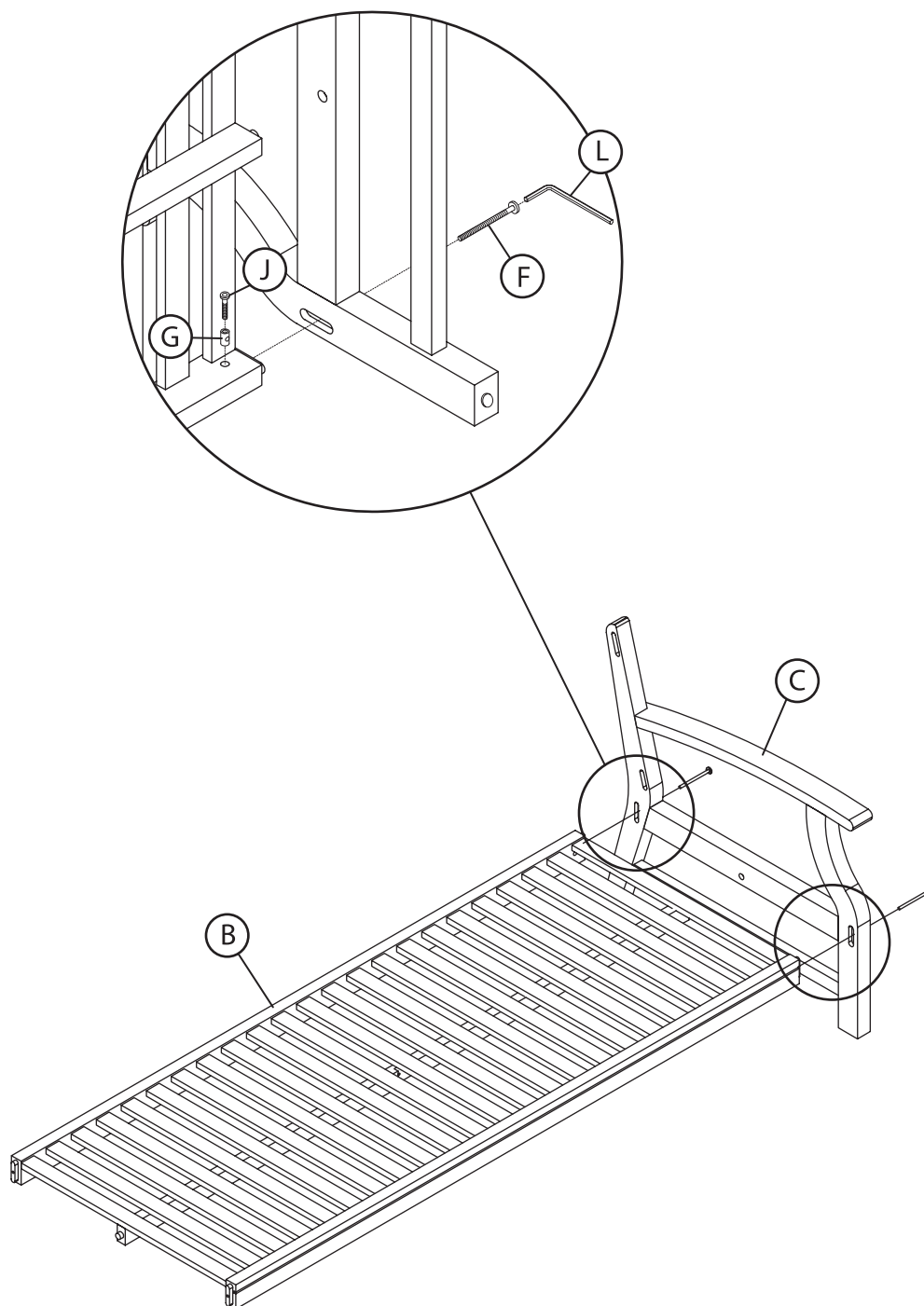

Étape 2.

ATTACHEZ LE DOSSIER À LA PATTE DE CADRAGE- Attachez le dossier (A) à la patte de cadrage (C) en utilisant les vis (E) et la clé Allen (L).

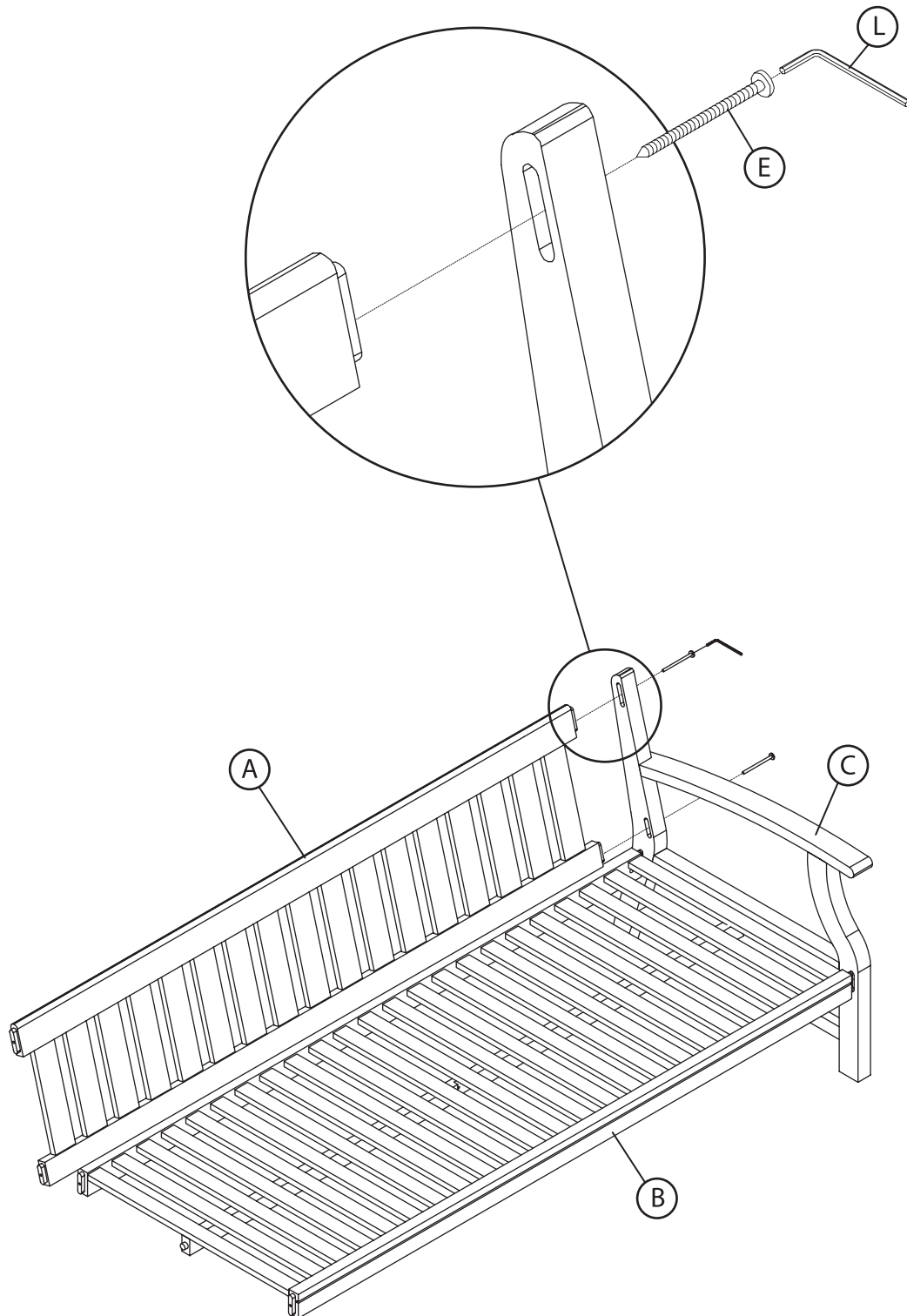

Étape 3.

ATTACHEZ LE SIÈGE ET LE DOSSIER À LA PATTE DE CADRAGE RESTANTE - Répétez les étapes 1 à 2 pour attacher le siège (B) et le dossier (A) à la patte de cadrage restante (C).

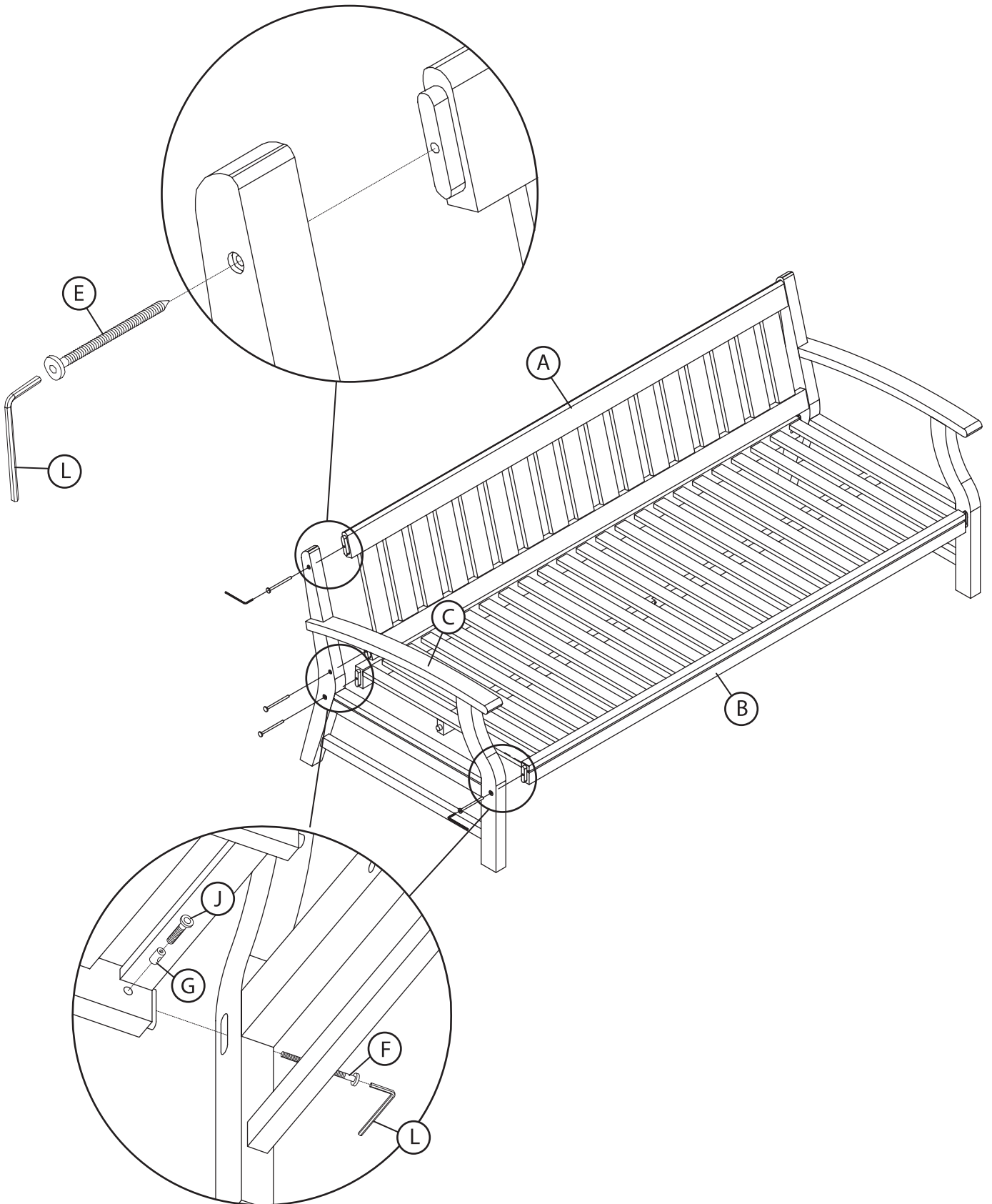

Étape 4.

ATTACHEZ LES PATTES ESCAMOTABLES AU SIÈGE - Attachez les pattes escamotables (D) au-dessous du siège (B) en utilisant les boulons (H), les capuchons pour boulons (I) et les clés Allen (L).

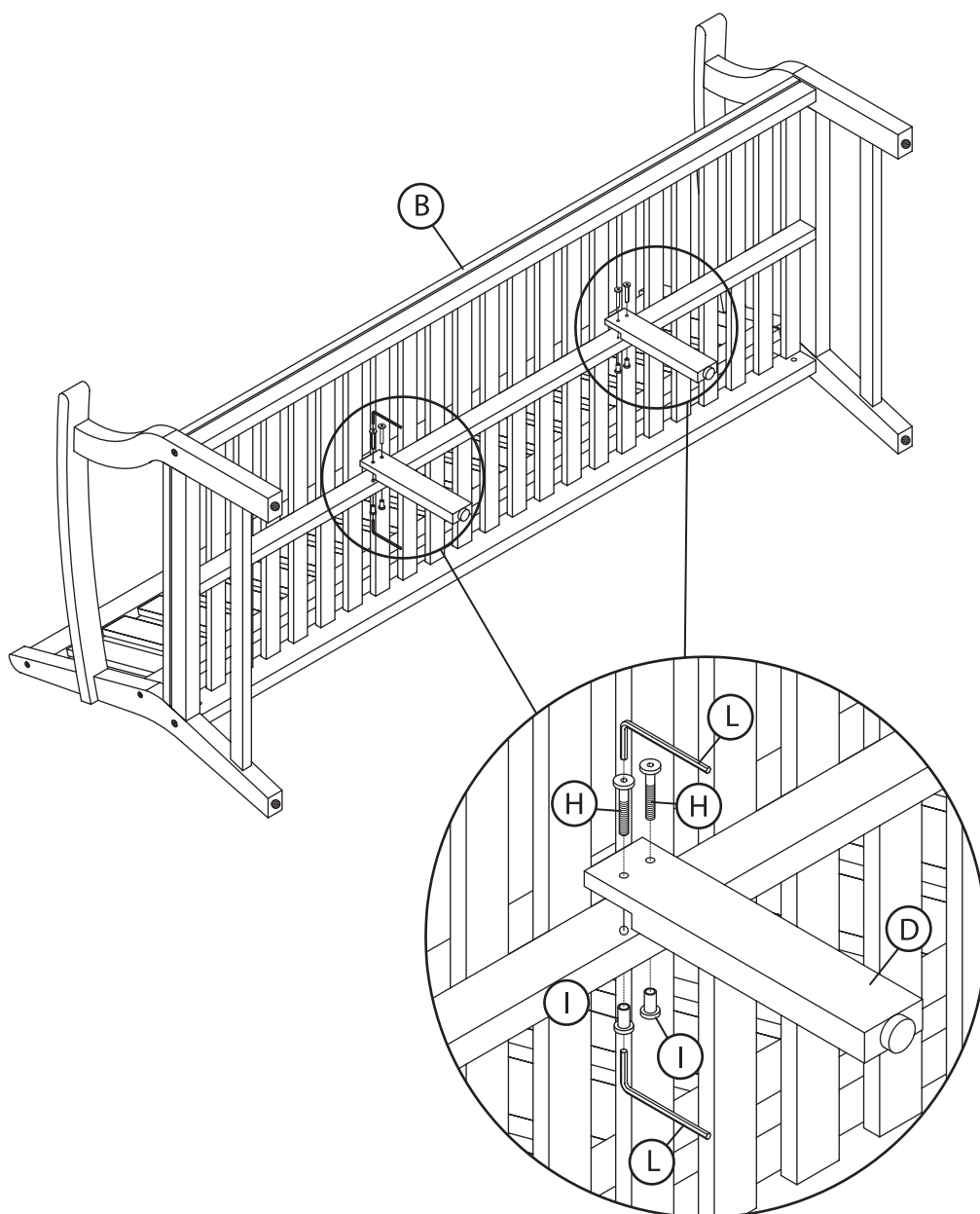

Étape 5.

INSÉREZ LES CAPUCHONS DE PLASTIQUE DANS LES TÊTES DES BOULONS -
Insérez les capuchons de plastique (K) dans les têtes apparentes des boulons que l'on retrouve sur les pattes de cadrage de la chaise.

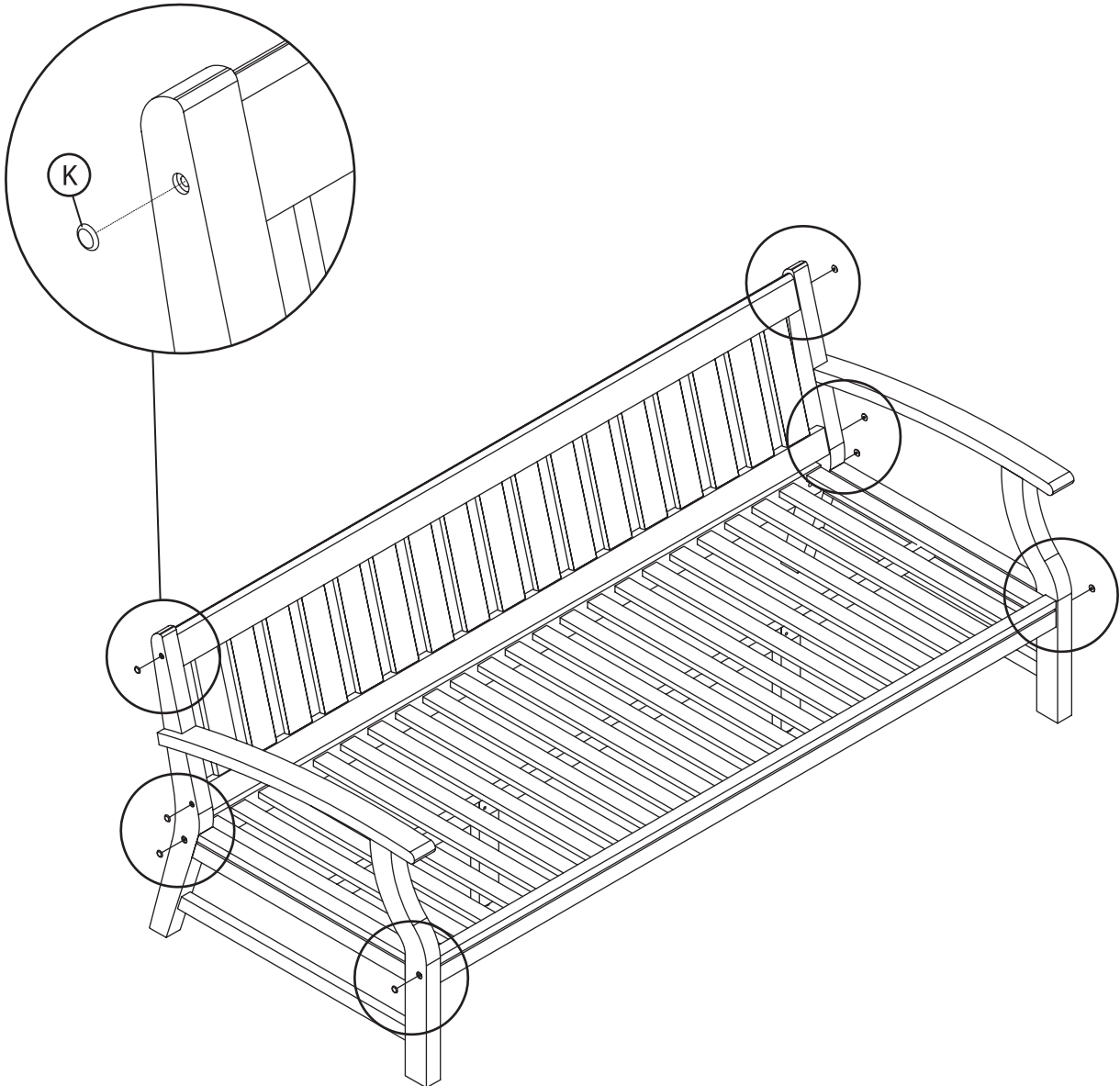

Soins et Entretien

Tout meuble à l'extérieur est soumis aux rayons UV ainsi qu'aux éléments météorologiques. Afin de préserver vos meubles aussi longtemps et aussi vibrants que possible, nous vous conseillons de les couvrir ou de les garder à l'intérieur lorsqu'ils ne sont pas utilisés. Pour plus d'informations sur les matériaux utilisés pour fabriquer nos meubles, veuillez visiter www.rstbrands.com/details-landing

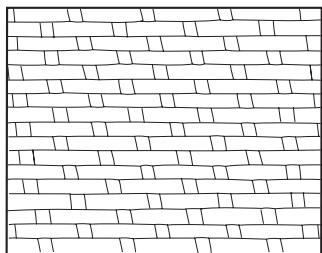

OSIER

Laver simplement vos meubles en osier avec un détergent léger, en les protégeant autant que peu se faire en les couvrant ou en les gardant à l'intérieur lorsqu'il ne sont pas utilisés, est suffisant.



CADRES EN ALUMINIUM

Les meubles RST Brands incorporent des cadres recouverts en aluminium qui sont conçus pour nécessiter un entretien minimum. Évitez de laisser trop de poussière s'empiler en les lavant avec du savon doux et de l'eau. Ne laissez jamais de meuble sous l'eau.

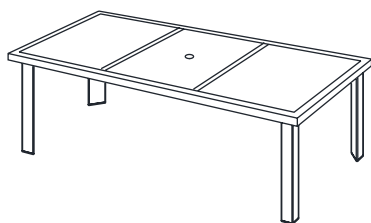

SURFACES EN PIERRE / DESSUS DE TABLE

Les liquides renversés doivent être nettoyés rapidement pour éviter toute tache sur la surface. Un lavage régulier avec un savon doux et de l'eau en utilisant une éponge ou une brosse souple est l'unique chose requise. Ranger ou couvrir votre surface en pierres naturelles lorsqu'elle n'est pas utilisée pendant une durée étendue est recommandé.

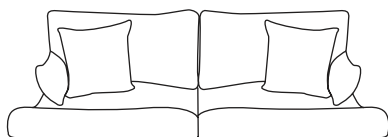

TISSUS

Nettoyez les liquides renversés avec un tissu et de l'eau. RST Brands utilise Sunbrella®, conçu pour protéger et durer pendant plusieurs années. Les tissus Sunbrella sont traités avec de l'eau et du produit anti-taches. Si nécessaire pour faire revivre les tissus, Glen Raven® recommande 303® Fabric Guard™. Pour plus d'informations, visiter www.303products.com et suivre les instructions présentes sur le conteneur.