

Thelix™

# 5 Piece Collection

Model: OP-ALSS5\_THLX

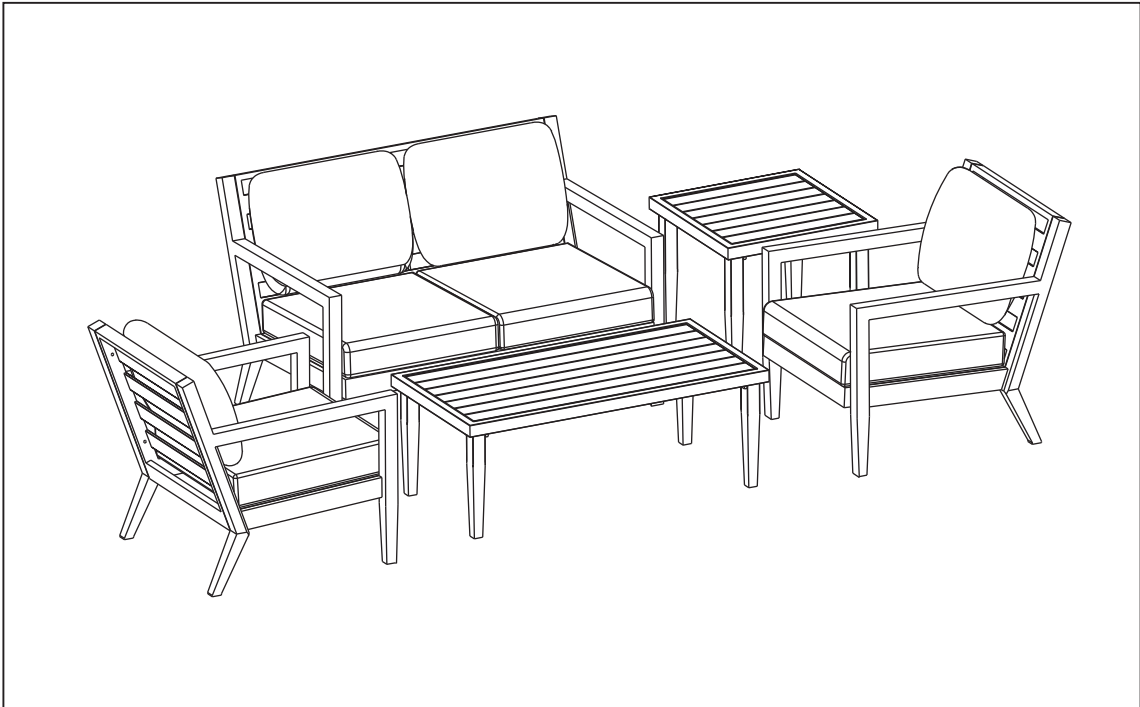

## ASSEMBLY INSTRUCTIONS





**IMPORTANT, RETAIN FOR FUTURE REFERENCE.  
READ CAREFULLY.**

For assistance with assembly or customer service,  
call 1-877-924-2090 (English) Monday-Friday, 8 a.m. to 5 p.m. Mountain  
Time, North America. Email: [customerservice@rstbrands.com](mailto:customerservice@rstbrands.com) or visit  
our website at [www.rstbrands.com](http://www.rstbrands.com)

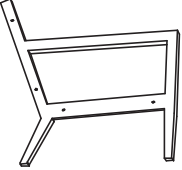
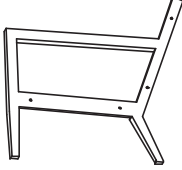

# PARTS LIST

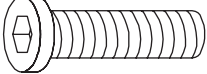

NO	PICTURE	PART DESCRIPTION	QTY.
A		Chair side	1
B		Chair side	1
C		Seat Frame	1
D		Bolt (M6 x 35)	8
E		Washer (15*8.5*1.0)	3
F		Allen wrench #4	1

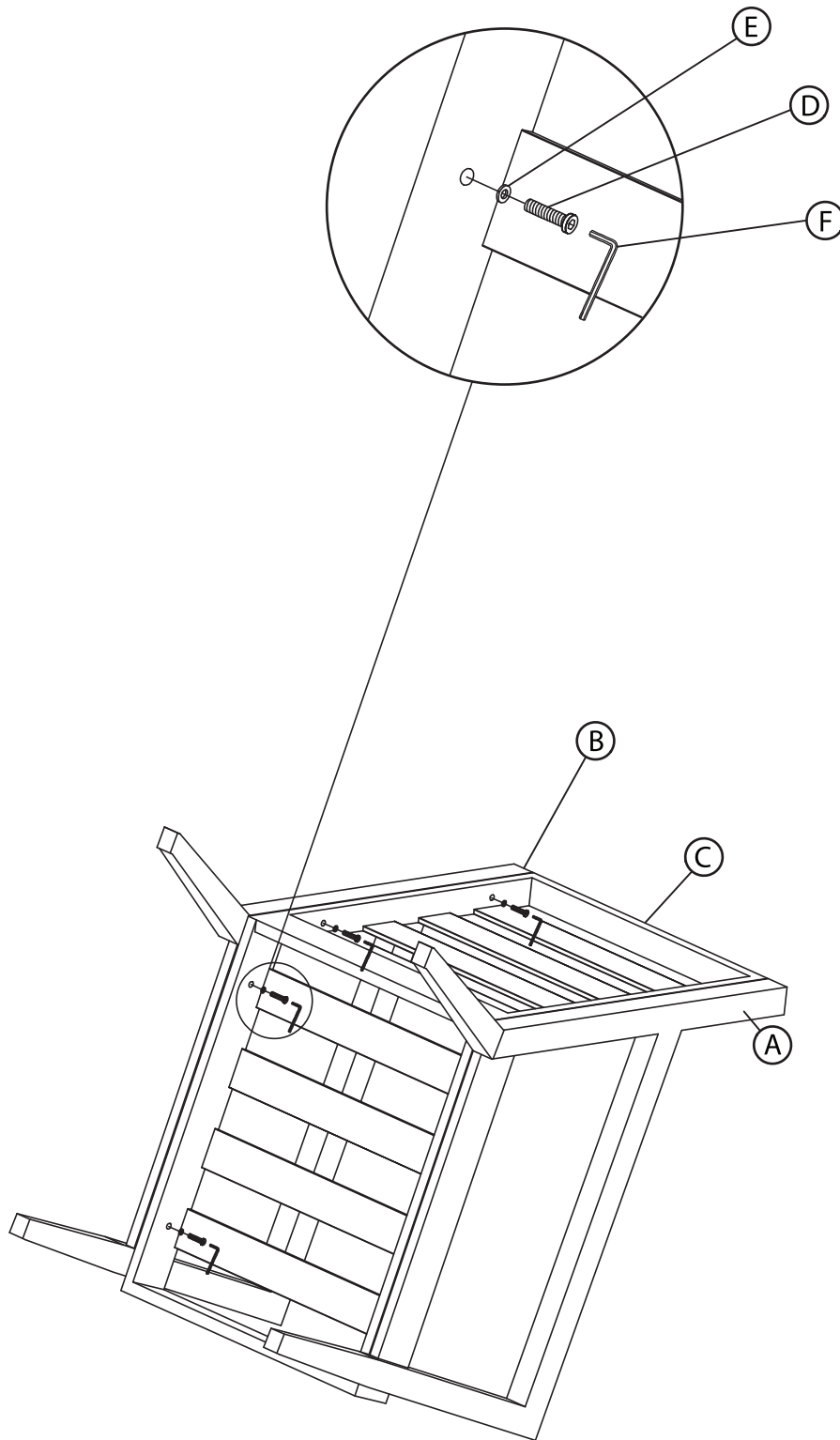

# Step 1.

**CONNECT CHAIR FRAME TO CHAIR SEAT-** Connect chair frames (A) and (B) to the seat (C) using washers (E), and allen wrench (F)

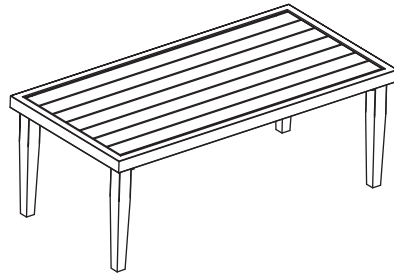

# PARTS LIST

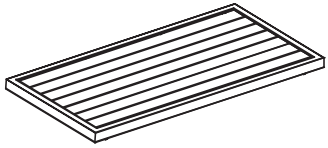

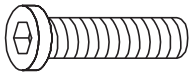
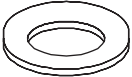
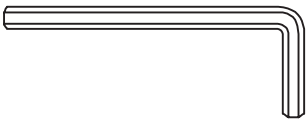
NO	PICTURE	PART DESCRIPTION	QTY.
A		Coffee Table top	1
B		Coffee Table legs	4
C		Bolt (M8 x 35)	8
D		Washer (15*8.5*1.0)	8
E		Allen wrench #4	1

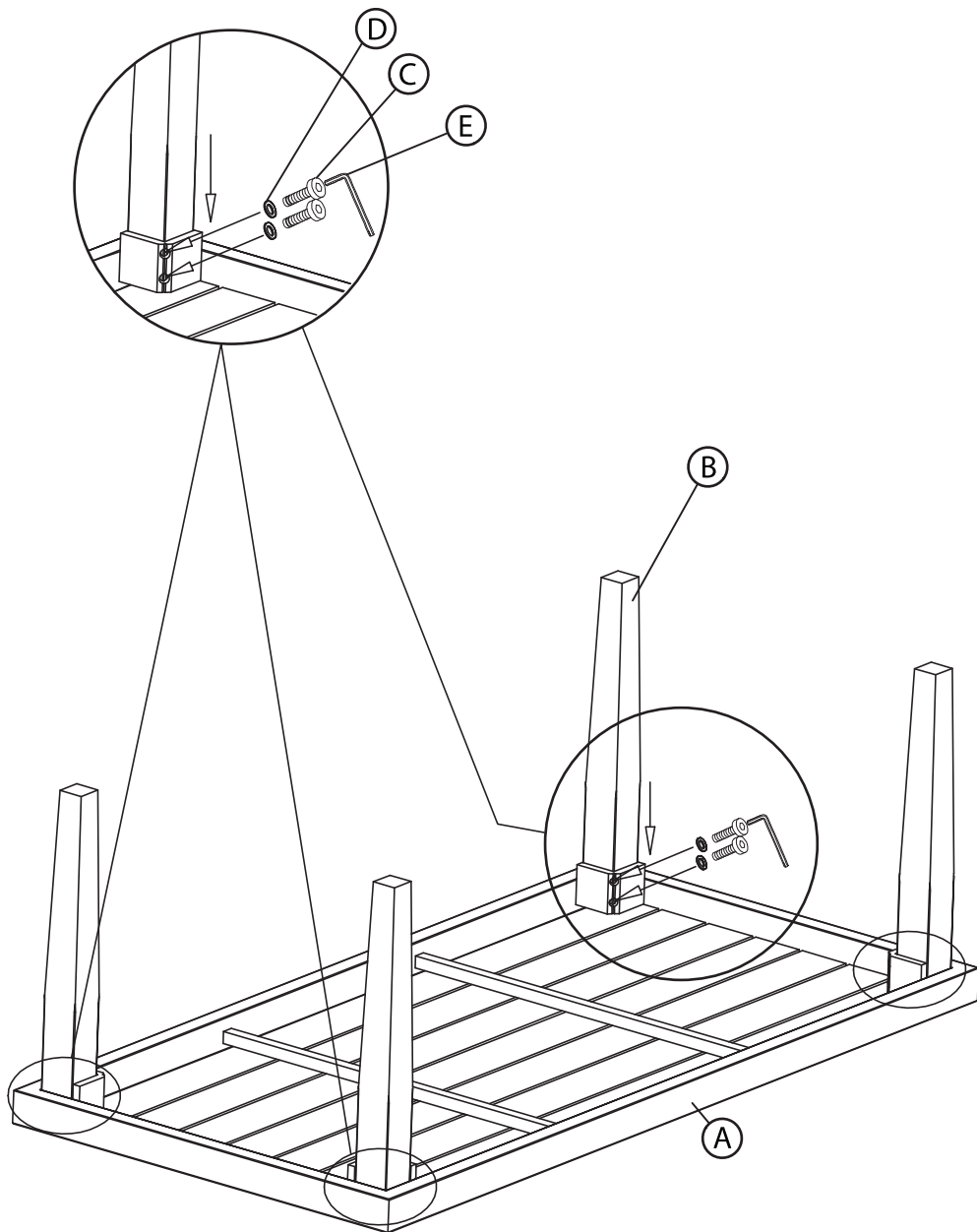

# Step 1.

**CONNECT TABLE LEGS TO TABLE TOP-** Connect table legs (B) to table top (A) with bolts (C) using washers (D), and allen wrench (E)

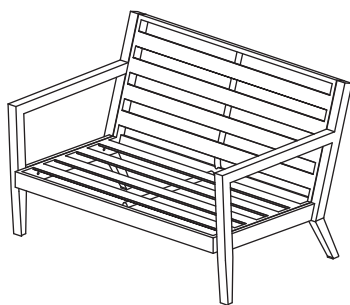

# PARTS LIST

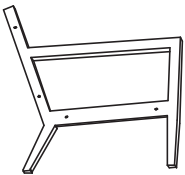
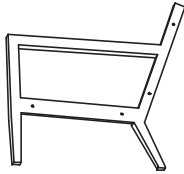
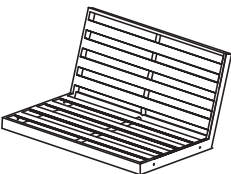
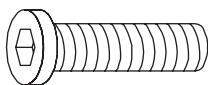
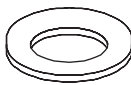

NO	PICTURE	PART DESCRIPTION	QTY.
A		Couch side	1
B		Couch side	1
C		Seat Frame	1
D		Bolt (M6 x 35)	8
E		Washer (15*8.5*1.0)	8
F		Allen wrench #4	1



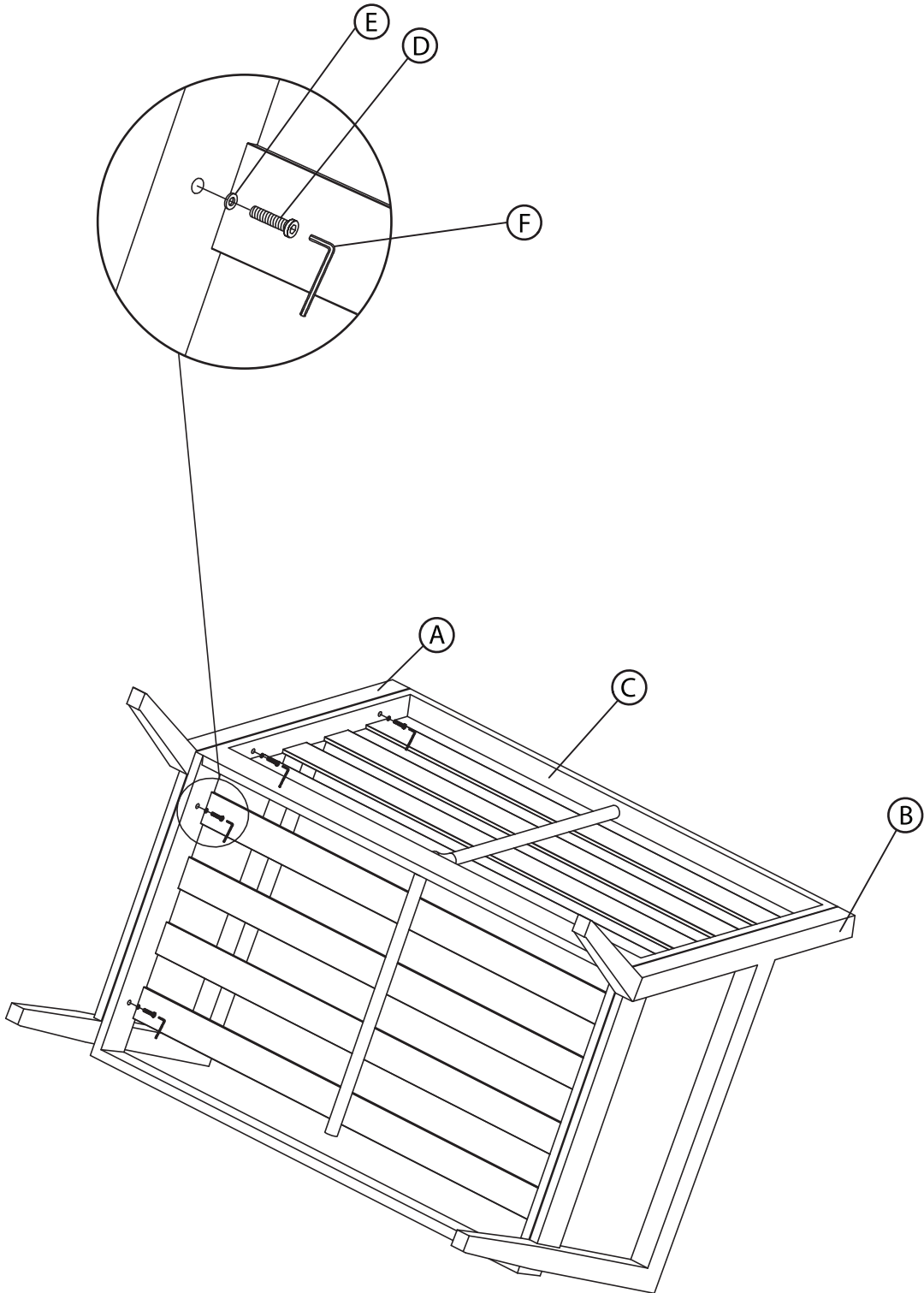

# Step 1.

**CONNECT COUCH FRAME TO COUCH SEAT-** Connect couch frames (A) and (B) to the seat (C) using bolts (D), washers (E), and allen wrench (F)

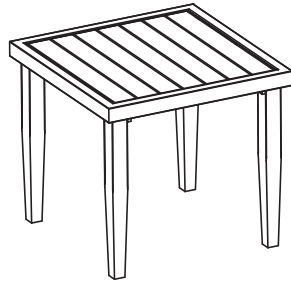

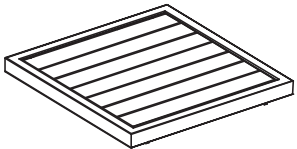
## PARTS LIST

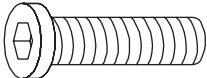
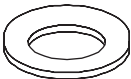

NO	PICTURE	PART DESCRIPTION	QTY.
A		Side Table Top	1
B		Side Table Leg	4
C		Bolt (M8 x 35)	8
D		Washer (15*8.5*1.0)	8
E		Allen wrench #4	1



# Step 1.

**CONNECT TABLE LEGS TO TABLE TOP-** Connect table legs (B) to table top (A) using bolts (C), washers (E), and allen wrench (F)

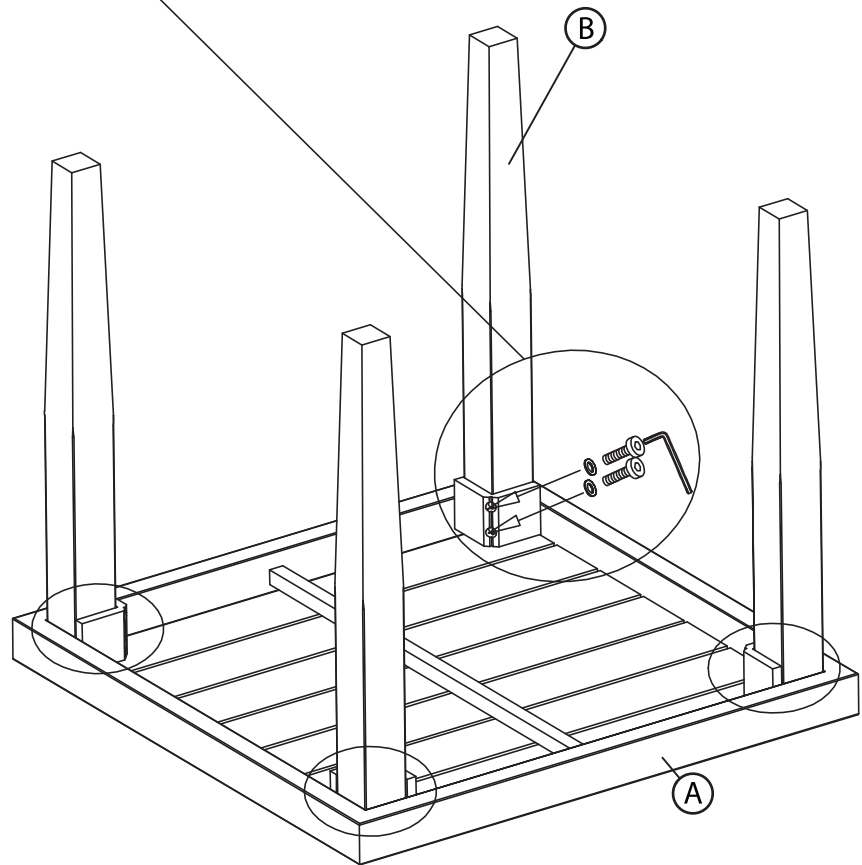
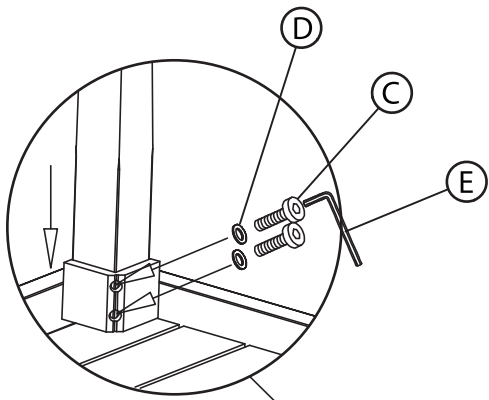

## Use and Care Manual

### General Maintenance Tips

All outdoor furniture is subject to UV rays and weather elements. In order to keep your furniture as long lasting and vibrant as possible, we advise using furniture covers or storing furniture when not in use. For more information about the materials used to make our furniture please visit [www.rstbrands.com/details-landing](http://www.rstbrands.com/details-landing)

---

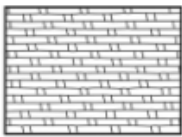

#### **Wicker**

Simply washing your wicker with a mild detergent and protecting it as much as possible by covering and or storing it when not in use for long periods of time is sufficient.



#### **Aluminum Frames**

RST Brands furniture incorporates aluminum powder coated frames that are designed to require minimum maintenance. Avoid letting too much dirt build up by cleaning with mild soap and water. Never leave furniture standing in water



#### **Tabletops**

Spills should be wiped up quickly to avoid any staining on the surface. Regular cleaning with mild soap and water with a sponge or soft scrub brush is all that is required. Storing or covering your natural stone top when not in use for extended periods of time is recommended



#### **Fabrics and Upholstery**

RST Brands uses high-quality poly fabrics designed to protect and last for several years of use and wear. Care for your upholstery by rinsing with water often and investing in furniture covers for colder months. To clean, wipe off spills with cloth and water

Thelix™

# Collection de 5 pièces

Modèle: OP-ALSS5\_THLX

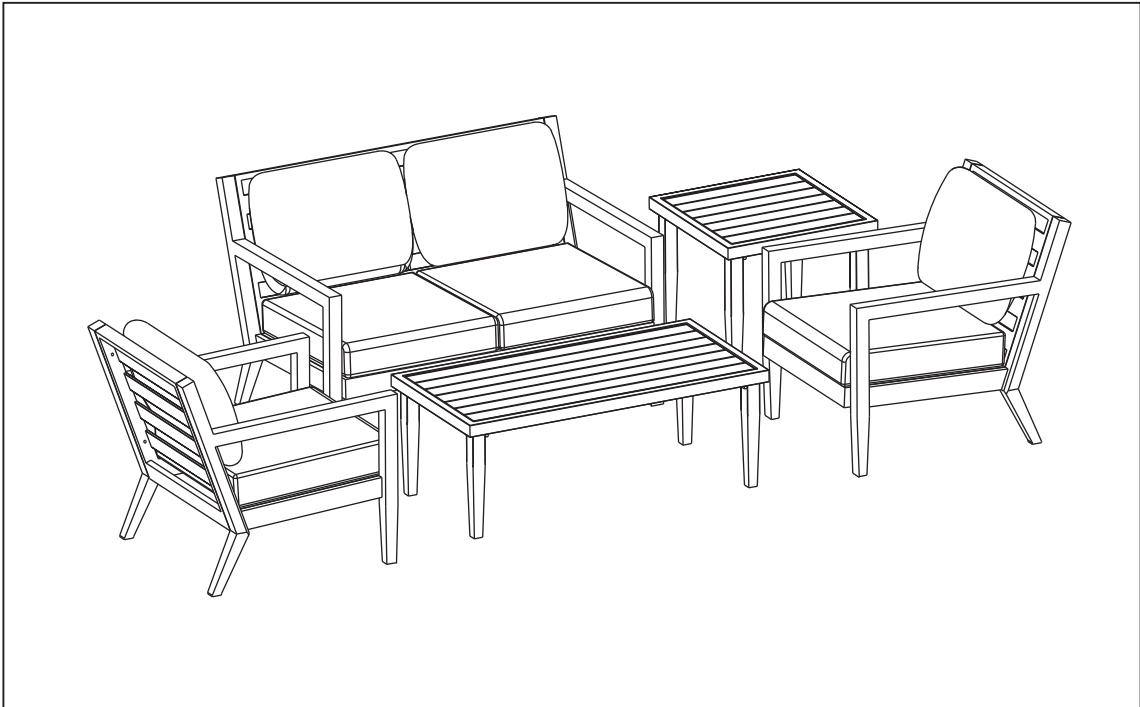

## INSTRUCTIONS D'ASSEMBLAGE





**IMPORTANT, À GARDER POUR RÉFÉRENCES FUTURES.  
À LIRE ATTENTIVEMENT.**

Pour obtenir de l'aide pour l'assemblage ou le service à la clientèle, composez le 1-877-924-2090 (Anglais) du lundi au vendredi, de 8 h à 17 h, heure de l'ouest, Amérique du Nord. Courriel: [customerservice@rst-brands.com](mailto:customerservice@rst-brands.com) ou visitez notre site Web à [www.rstbrands.com](http://www.rstbrands.com).

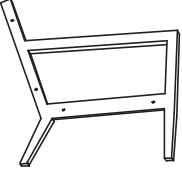
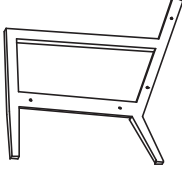

# LISTE DES PIÈCES

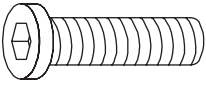
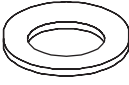

NO	PHOTO	DESCRIPTION DE LA PIÈCE	QTÉ
A		Coté de chaise	1
B		Coté de chaise	1
C		Cadre du siège	1
D		Boulon (M6 x 35)	8
E		Rondelle (15*8,5*1,0)	3
F		Clé Allen # 4	1

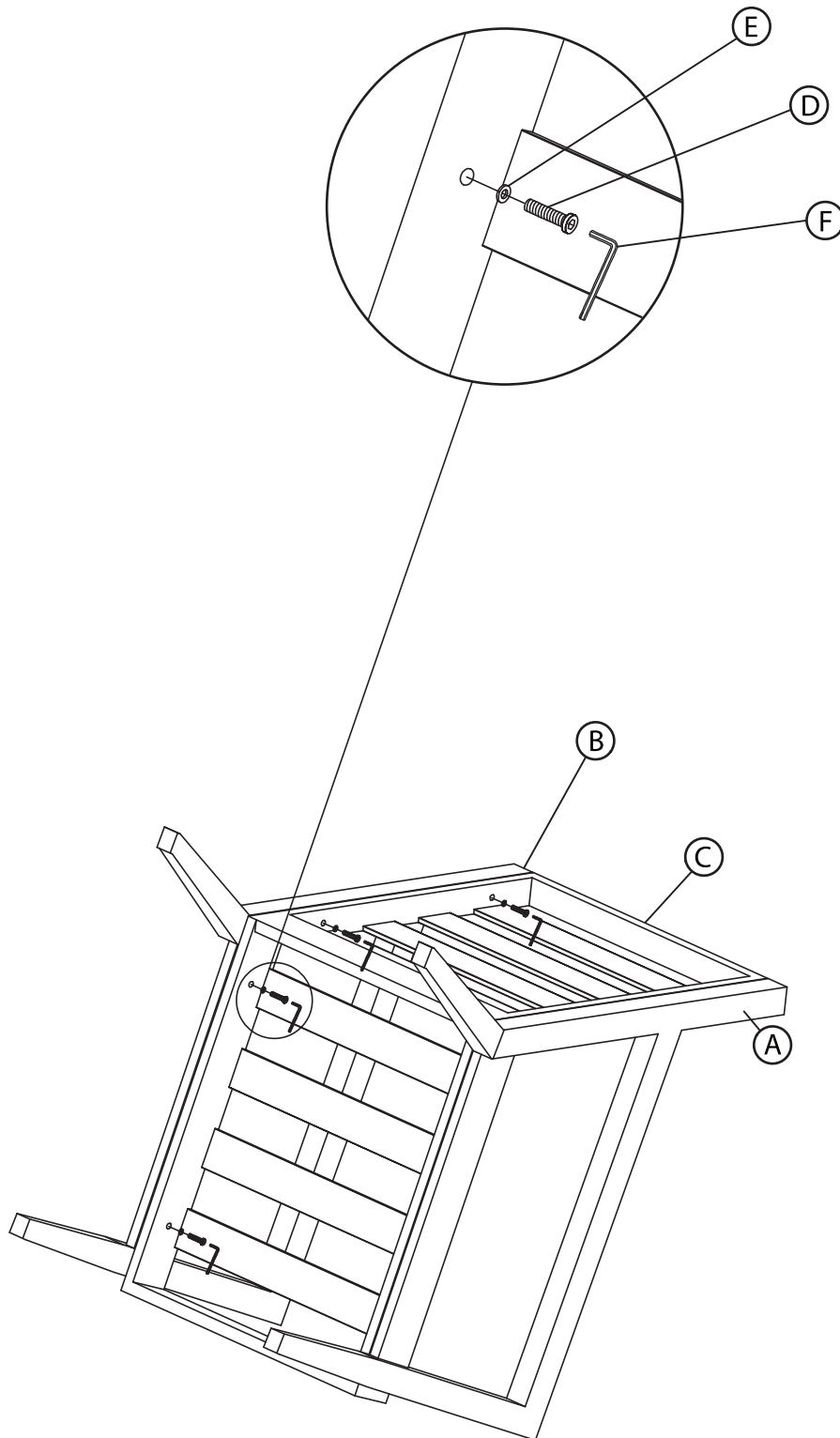

## Étape 1.

**CONNECTEZ LE CADRE DE LA CHAISE AVEC LE SIÈGE-** Connectez le cadre de la chaise (A) et (B) au siège (C) en utilisant les rondelles (E) et la Clé Allen (F).

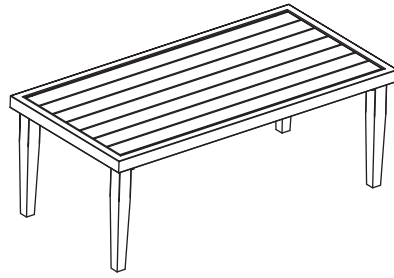

# LISTE DES PIÈCES

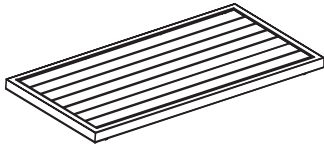

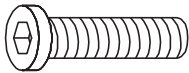
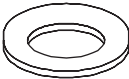
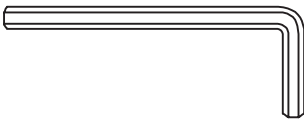
NO	PHOTO	DESCRIPTION DE LA PIÈCE	QTÉ
A		Dessus de la table à café	1
B		Pattes de table à café	4
C		Boulon (M8 x 35)	8
D		Rondelle (15*8,5*1,0)	8
E		Clé Allen # 4	1

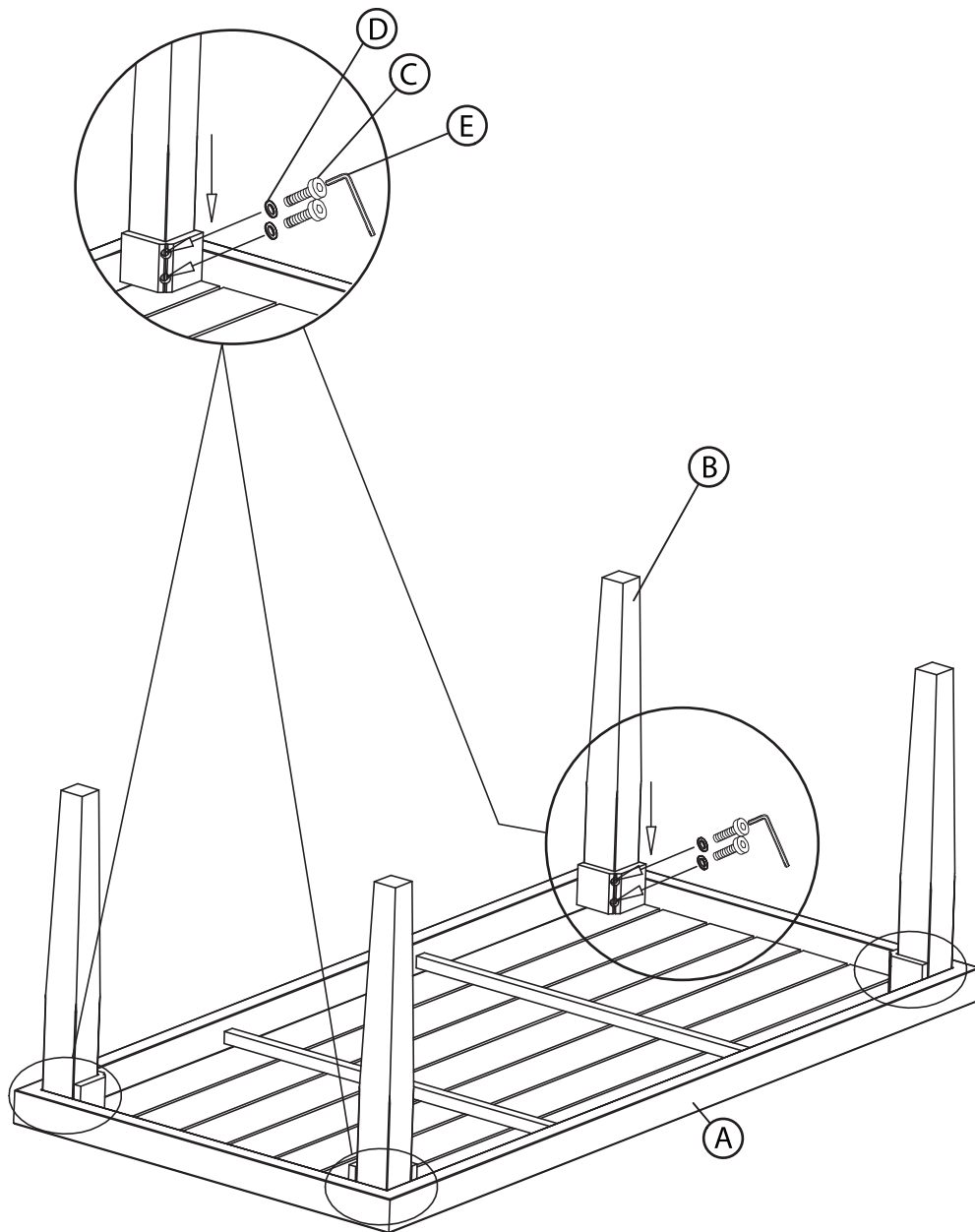

# Étape 1.

**CONNECTEZ LES PATTES DE TABLES AVEC LE DESSUS DE TABLE-** Connectez les pattes de table (B) au dessus de la table (A) avec les boulons (C) en utilisant les rondelles (D), et la clé Allen (E)

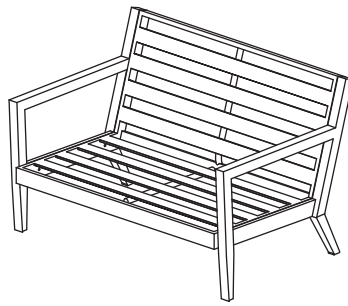

# LISTE DES PIÈCES

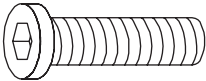

NO	PHOTO	DESCRIPTION DE LA PIÈCE	QTÉ
A		Coté du divan	1
B		Coté du divan	1
C		Cadre du siège	1
D		Boulon (M8 x 35)	8
E		Rondelle (15*8,5*1,0)	8
F		Clé Allen # 4	1



# Étape 1.

**CONNECTEZ LE CADRE DU DIVAN AVEC LE SIÈGE** - Connectez les cadres (A) et (B) au siège (C) en utilisant les boulons (D), les rondelles (E) et la clé Allen (F).

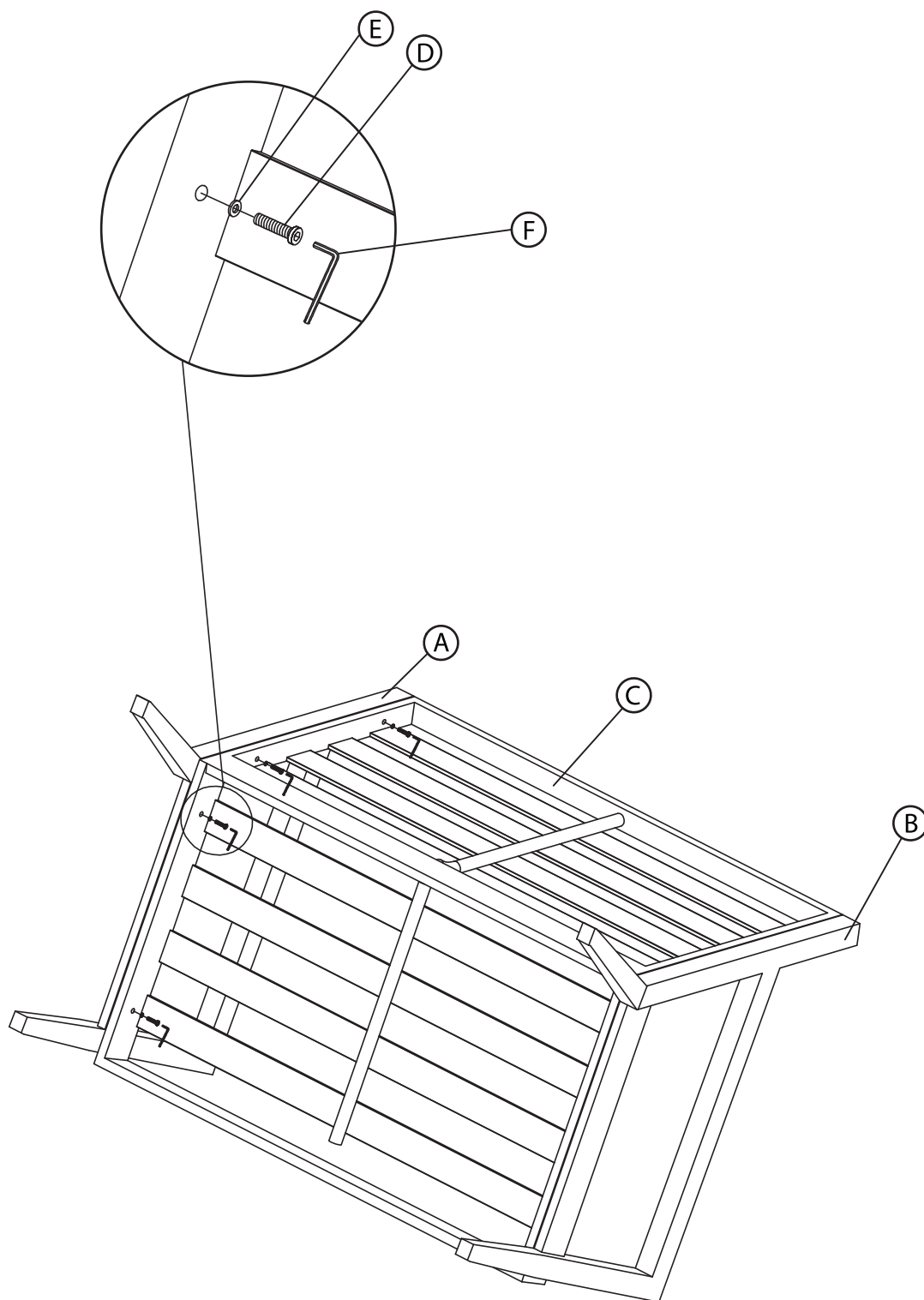

# LISTE DES PIÈCES

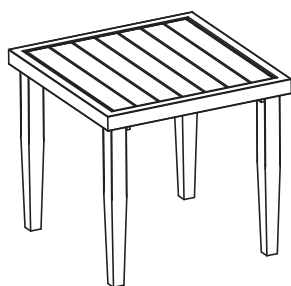

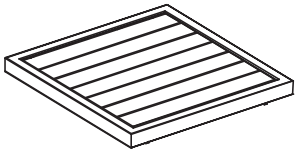
NO	PHOTO	DESCRIPTION DE LA PIÈCE	QTÉ
A		Dessus de la table de chevet	1
B		Dessus de la table de chevet	4
C		Boulon (M8 x 35)	8
D		Rondelle (15*8,5*1,0)	8
E		Clé Allen # 4	1

# Étape 1.

**CONNECTEZ LES PATTES DE TABLES AVEC LE DESSUS DE TABLE-** Connectez les pattes de table (B) au dessus de la table (A) en utilisant les boulons (C), les rondelles (E) et la clé Allen (F).

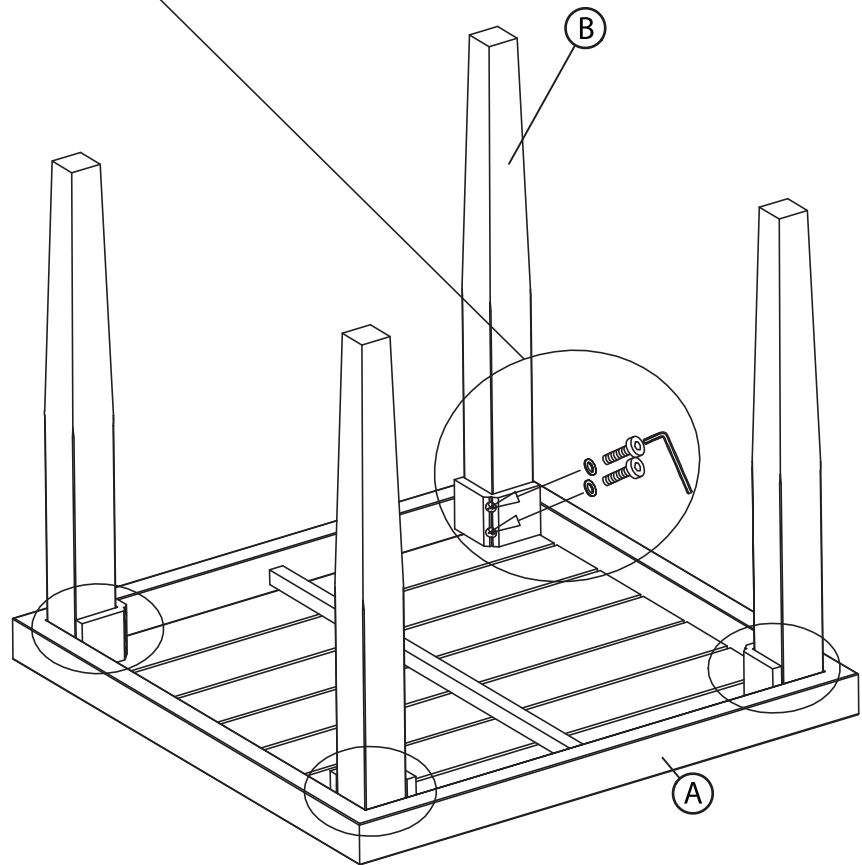
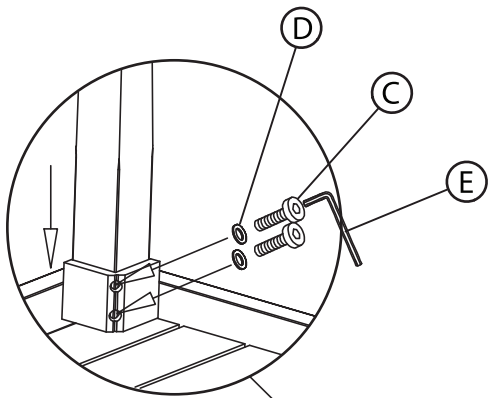

## General Maintenance Tips

Toutes les fournitures extérieures sont sujettes aux rayons UV et aux intempéries. Dans le but de garder votre fourniture le plus longtemps possible, nous vous recommandons d'utiliser des housses de protection ou ranger vos meubles lorsqu'ils ne sont pas utilisés. Pour plus d'informations concernant les matériaux utilisés, visitez le site: [www.rstbrands.com/details-landing](http://www.rstbrands.com/details-landing)

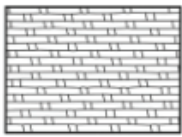

### Osier

Nettoyez votre osier en toute simplicité avec un détergent doux et protégez-le le plus possible en le couvrant ou en le rangeant lorsqu'il n'est pas utilisé pendant de longues périodes.



### Cadres en aluminium

Les meubles de RST Brands incorpore de la poudre d'aluminium dans leurs revêtements de cadres, conçus pour nécessiter un minimum d'entretien. Évitez de laisser trop de saleté s'accumuler en nettoyant avec un savon doux et de l'eau. Ne laissez jamais les meubles immergés dans l'eau.



### Dessus de table

Les dégâts doivent être essuyés rapidement pour éviter toute tache sur la surface. Un nettoyage régulier avec un savon doux et de l'eau avec une éponge ou une brosse à récurer douce est tout ce qui est nécessaire. Il est recommandé de ranger ou de couvrir votre dessus en pierre naturelle lorsqu'il n'est pas utilisé pendant de longues périodes.



### Tissus et rembourrage

RST Brands utilise des tissus poly de haute qualité conçus pour protéger et durer plusieurs années d'utilisation et d'usure. Prenez soin de vos tissus d'ameublement en les rinçant souvent à l'eau et en investissant dans des housses de meubles pour les mois les plus froids. Pour nettoyer, essuyez les éclaboussures avec un chiffon et de l'eau.

Thelix™

# Colección de 5 piezas

Modelo: OP-ALSS5\_THLX

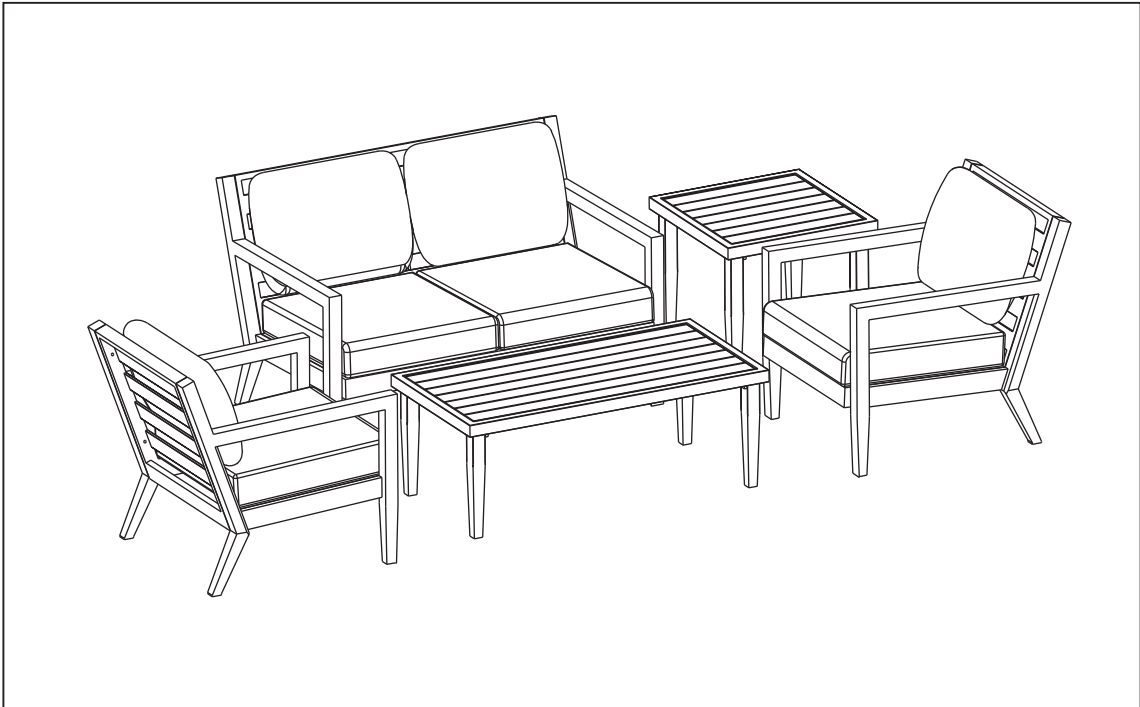

## INSTRUCCIONES DE ENSAMBLAJE





**IMPORTANTE: GUARDE PARA CONSULTAR EN EL FUTURO.  
LEA CUIDADOSAMENTE.**

Para obtener ayuda con el ensamblaje o para contactar a servicio al cliente, llame al 1-877-924-2090 (inglés) de lunes a viernes, de 8 a.m. a 5 p.m. (Hora de la montaña de América del Norte), envíe un correo electrónico a: [customerservice@rstbrands.com](mailto:customerservice@rstbrands.com), o visite nuestro sitio web en: [www.rstbrands.com](http://www.rstbrands.com).

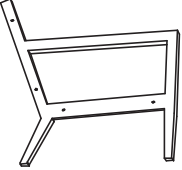
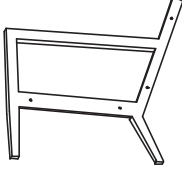

# LISTA DE PARTES

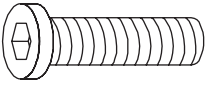
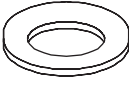

NO	IMAGEN	DESCRIPCIÓN DE LA PARTE	CANT.
A		Lado de la silla	1
B		Lado de la silla	1
C		Marco del asiento	1
D		Perno (M6 x 35)	8
E		Arandela (15* 8.5* 1.0)	3
F		Llave Allen # 4	1

# Paso 1.

**CONECTE EL MARCO AL ASIENTO DE LA SILLA:** Conecte los lados de la silla (A) y (B) al asiento (C) utilizando las arandelas (E) y la llave Allen (F).

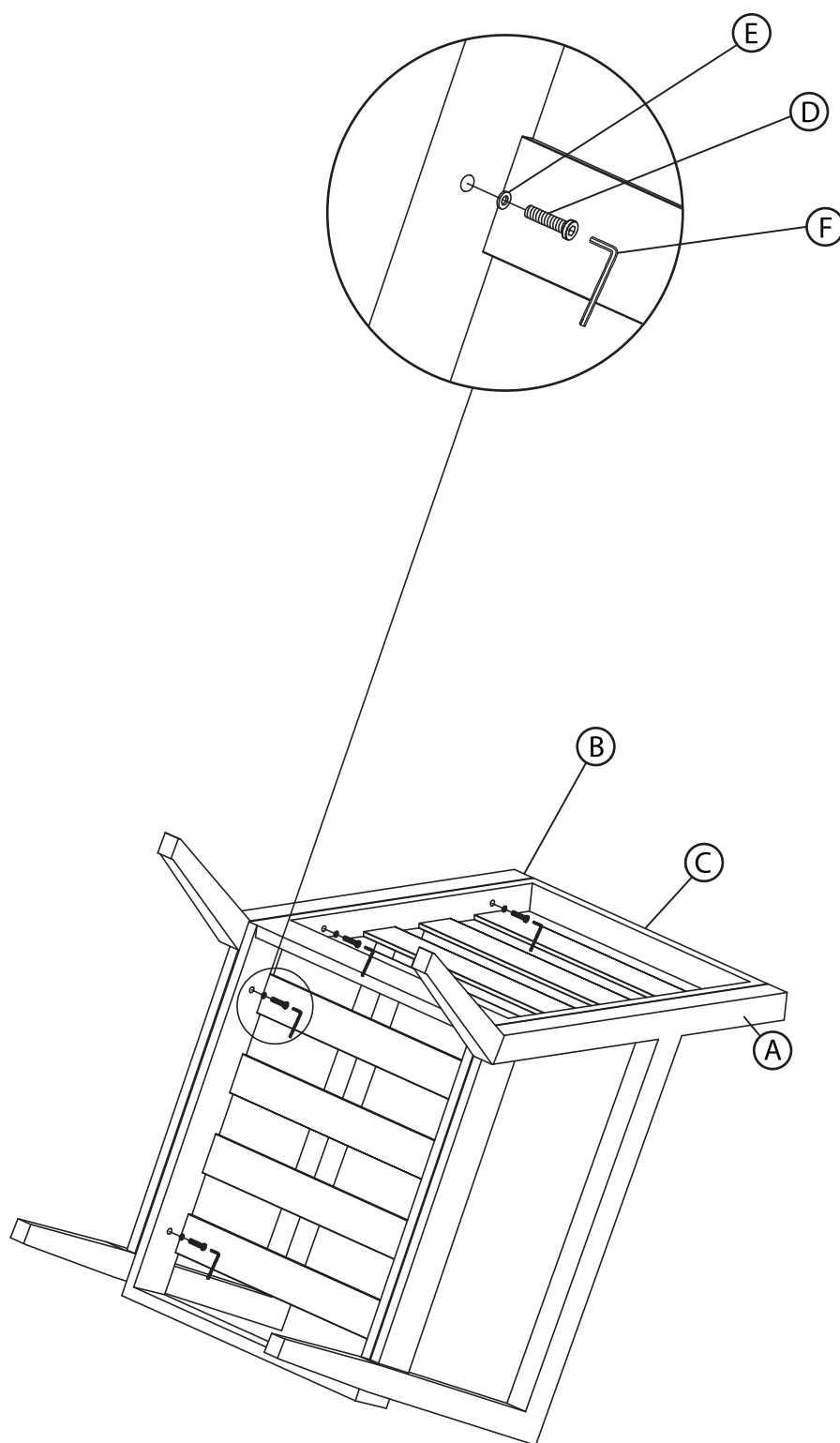

# LISTA DE PARTES

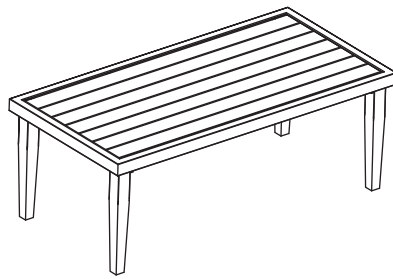

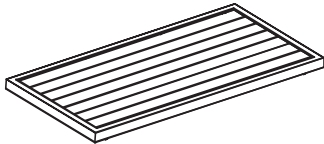
NO	IMAGEN	DESCRIPCIÓN DE LA PARTE	CANT.
A		Superficie de la mesa	1
B		Patas de la mesa	4
C		Perno (M8 x 35)	8
D		Arandela (15 * 8.5 * 1.0)	8
E		Llave Allen # 1	1



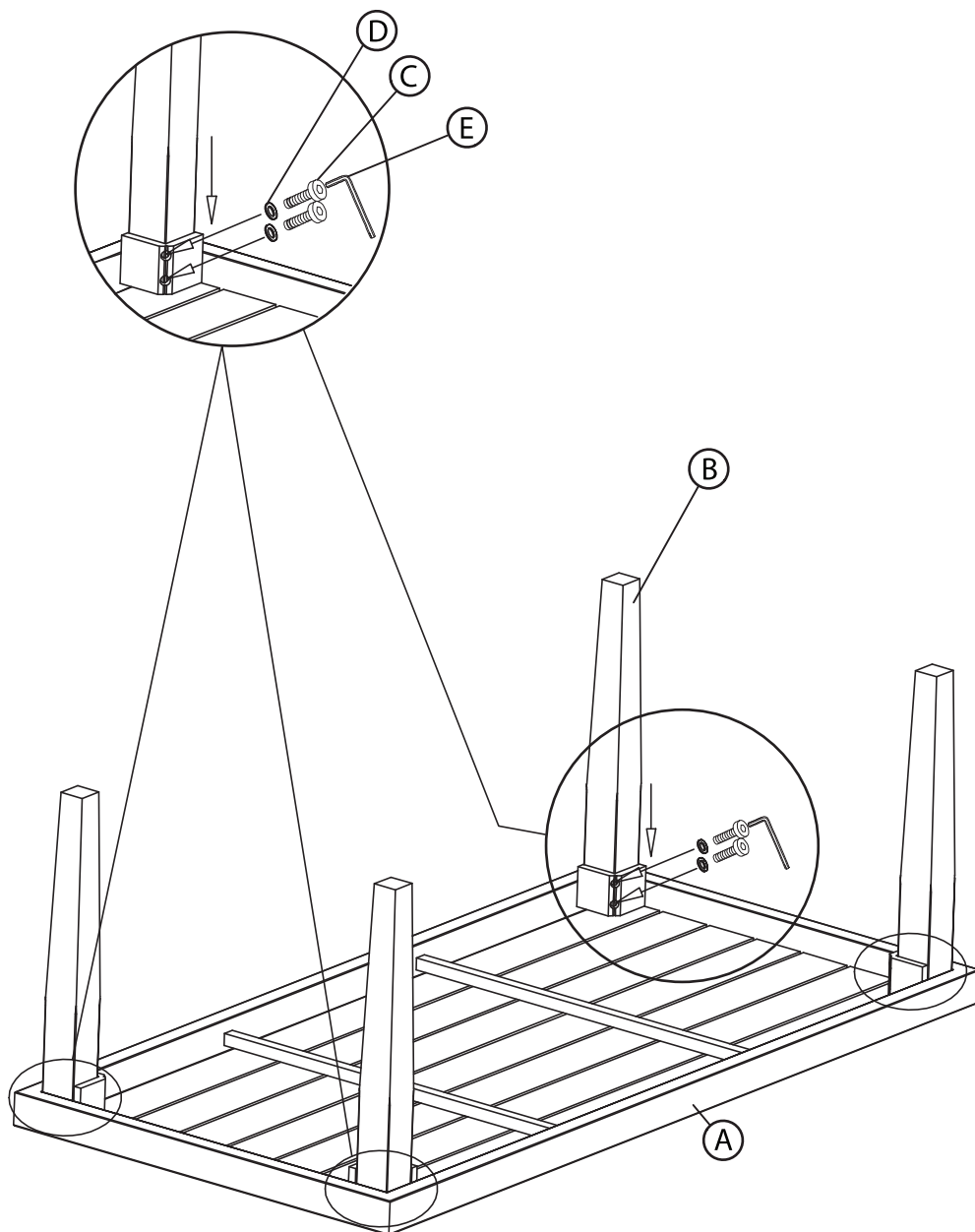

# Paso 1.

**CONECTE LAS PATAS A LA SUPERFICIE DE LA MESA:** Conecte las patas (B) a la superficie de la mesa (A) utilizando los pernos ©, las arandelas (D) y la llave Allen (E).

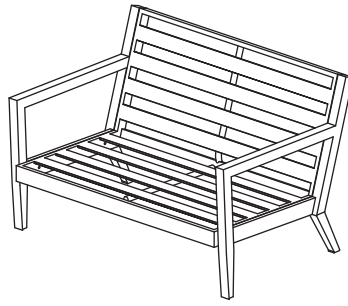

# LISTA DE PARTES

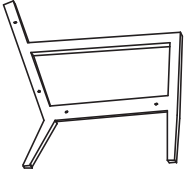
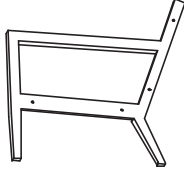
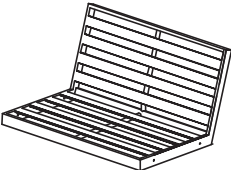
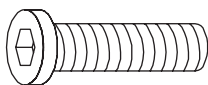
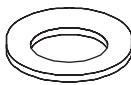

NO	IMAGEN	DESCRIPCIÓN DE LA PARTE	CANT.
A		Lado del sofá	1
B		Lado del sofá	1
C		Estructura del asiento	1
D		Perno (M6 x 35)	8
E		Arandela (15 * 8.5 * 1.0)	8
F		Llave Allen # 4	1

## Paso 1.

**CONECTE EL MARCO AL ASIENTO DEL SOFÁ:** Conecte los lados del sofá (A) y (B) al asiento (C) utilizando los tornillos (D), las arandelas (E) y la llave Allen (F).

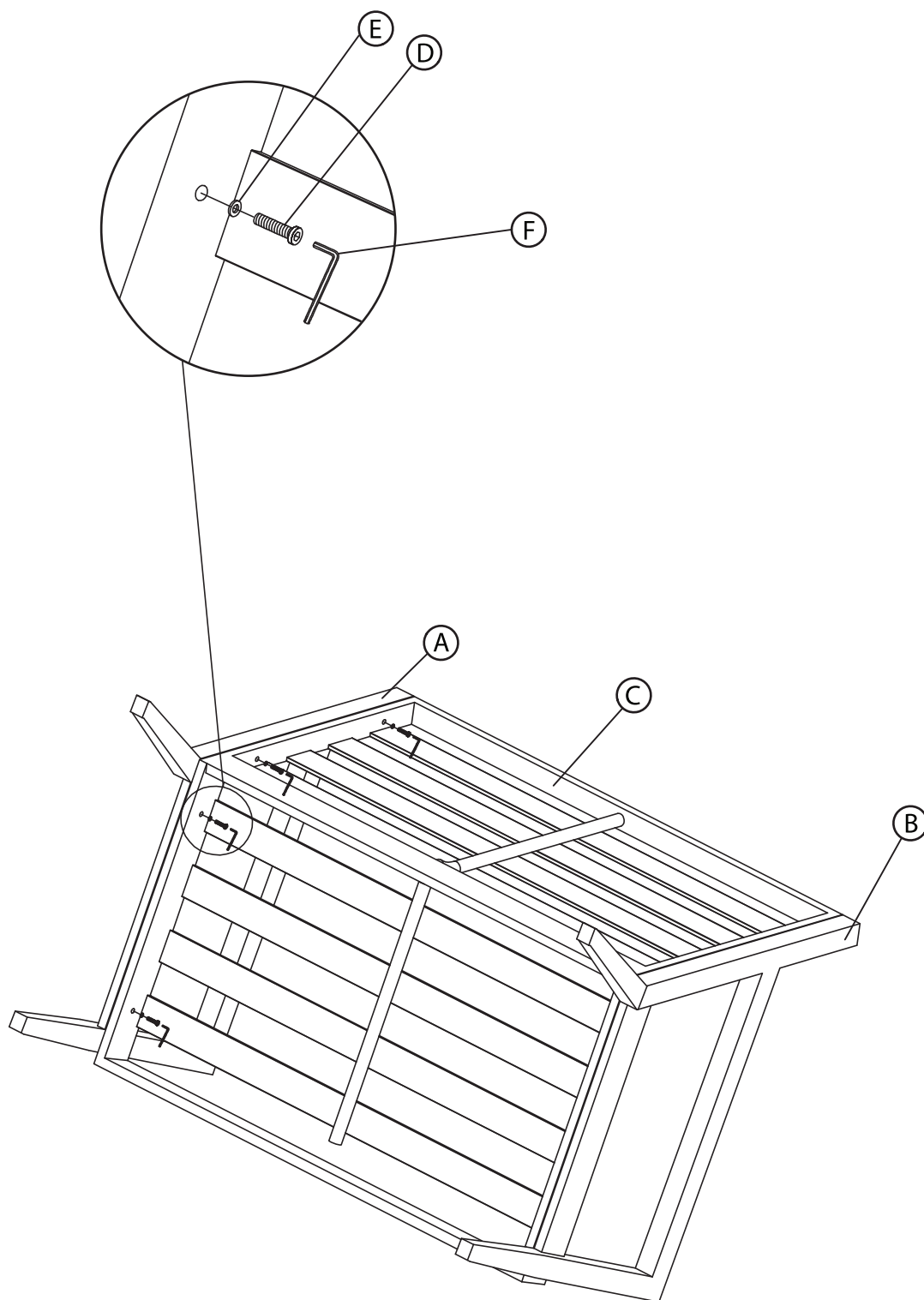

# LISTA DE PARTES

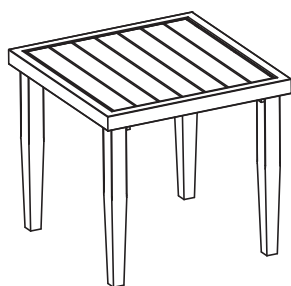

NO	IMAGEN	DESCRIPCIÓN DE LA PARTE	CANT.
A		Superficie de la mesa auxiliar	1
B		Pata de mesa auxiliar	4
C		Perno (M8 x 35)	8
D		Arandela (15 * 8.5 * 1.0)	8
E		Llave Allen # 4	1

# Paso 1.

**CONECTE LAS PATAS A LA SUPERFICIE DE LA MESA:** Conecte las patas (B) a la superficie de la mesa (A) utilizando los pernos (C), las arandelas (E) y la llave Allen (F).

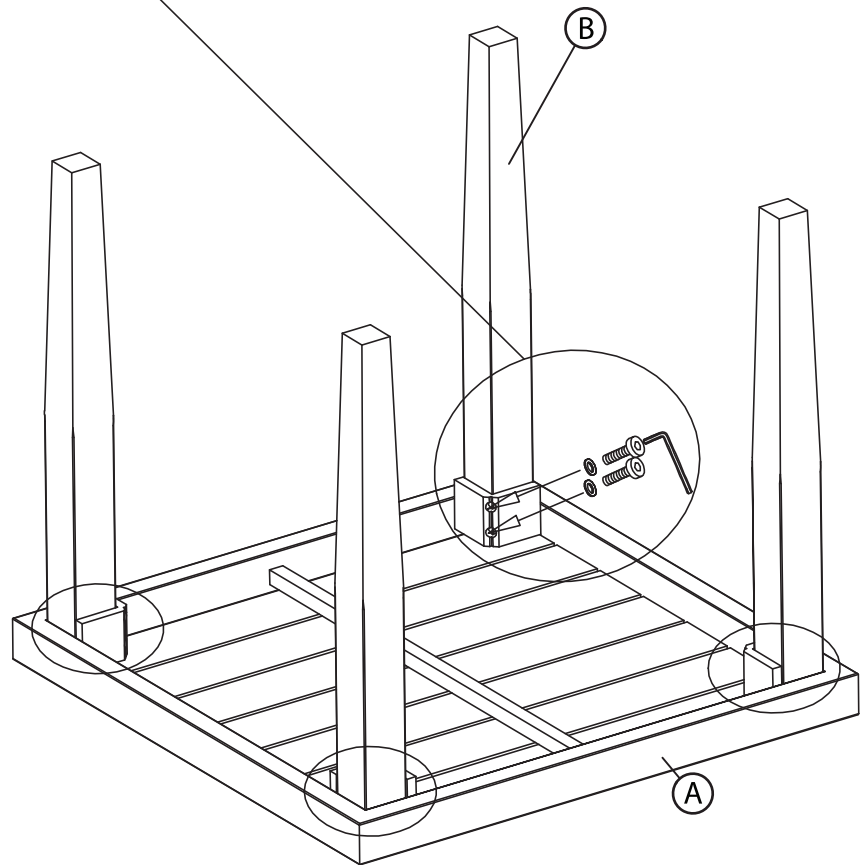
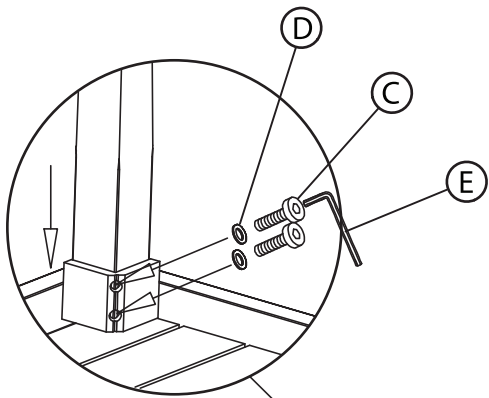

# Manual de uso y cuidado

## General Maintenance Tips

Todo mobiliario para exteriores está expuesto a los rayos ultravioleta y las inclemencias meteorológicas. Para que sus muebles duren y los colores se mantengan tan vibrantes como sea posible, aconsejamos cubrirlos o guardarlos cuando no estén en uso. Para obtener más información acerca de los materiales que utilizamos para fabricar nuestros muebles visite: [www.rstbrands.com/details-landing](http://www.rstbrands.com/details-landing)

---

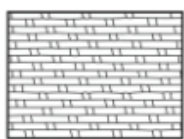

### Mimbre

Simplemente limpie sus muebles de mimbre con un detergente suave y protéjalos cubriéndolos o guardándolos cuando no los use durante largos períodos de tiempo.



### Estructuras de aluminio

Los muebles de RST Brands están contruidos con estructuras recubiertas con polvo de aluminio diseñados para necesitar muy poco mantenimiento. Evite que se acumule demasiada suciedad limpiando con agua y jabón suave. Nunca deje muebles sobre el agua.



### Superficie de las mesas

Limpie los derrames rápidamente para evitar manchas en la superficie. La limpieza regular con agua y jabón suave con una esponja o cepillo es todo lo que se necesita. Se recomienda almacenar o cubrir la superficie de piedra natural cuando no está en uso durante períodos de tiempo prolongados.



### Tejidos

RST Brands utiliza telas de poliéster de alta calidad diseñadas para proteger y durar varios años de uso y desgaste. Cuide su tapizado enjuagándolo con agua a menudo e invirtiendo en fundas para muebles para los meses más fríos. Para limpiar, limpie los derrames con un paño y agua.